

G5 SERIES CATALOG

LEADING THE WORLD'S BEST IMM



WOOJIN
PLAIMM

LEADING THE WORLD'S BEST INJECTION MOLDING MACHINE

· Facility Area: 485,867m²
 · Total Area: 690,506m²

WOOJIN PLAIMM HISTORY

- 1985.04: Woojin Machinery established
- 1998.04: Developed high-performance small IMM SELEX-ELF
- 1999.11: Developed two-platen IMM SELEX-TM
- 2000.03: Developed all-electric IMM SELEX-EA
- 2001.02: Company name change-Woojin Selex Co., Ltd.
- 2004.06: Developed double IMM SELEX-NC
- 2005.12: Developed the first IMM for PET preforms in Korea
- 2006.03: Korea's first injection speed 1,600mm/sec ultra high speed, ultra precision IMM development
- 2007.05: Developed an IMM for lens only
- 2007.07: Developed a hybrid IMM (NM-130H)
- 2008.01: Developed an IMM for stack & tandem mold
- 2009.05: Developed a new concept IMM (TH, TE, DL, VH Series)
- 2012.03: Company name change-Woojin Plaimm Co., Ltd.
- 2014.07: Established the second research corporation in Austria (WOOJIN PLAIMM GmbH)
- 2014.10: Established the first IMM business site in Korea (Woojin Technovelli) and relocated the business site (Incheon → Boeun)
- 2018.11: Developed the world's first low-pressure physical foam IMM (Super-Foam)
- 2019.11: Launch SPEED CLUB app and opening of the CS center
- 2021.08: Developed Super-Foam vertical (SFV2400)
- 2023.03: Developed premium tie-bar less IMM TL-A5
 Developeed premium two-platen hybrid multi IMM (DL-2K-T)

IN-HOUSE PRODUCTION

Frame

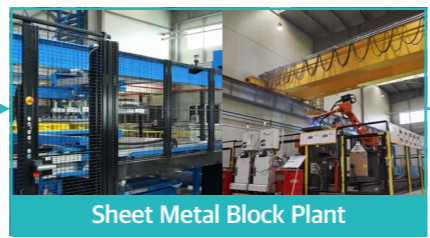

Platen · Toggle



Smart Storage

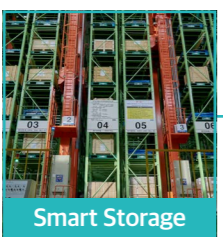

Plasticization



Woojin Plaimm G5 series is widely used
in automobiles, home appliances,
electronics, medical etc.

We provide optimal solutions for production in
various plastic products.

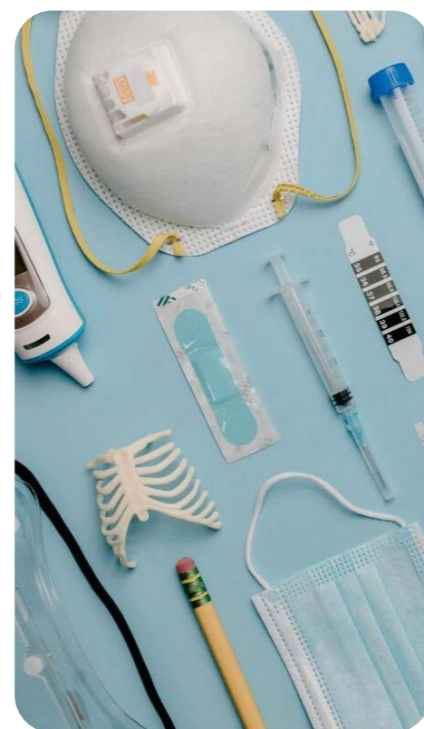

G5 Series line-up

DL-G5 - Power-saving two platen IMM (450~4300 ton)



TB-G5 - Power-saving hydraulic IMM (90~880 ton)

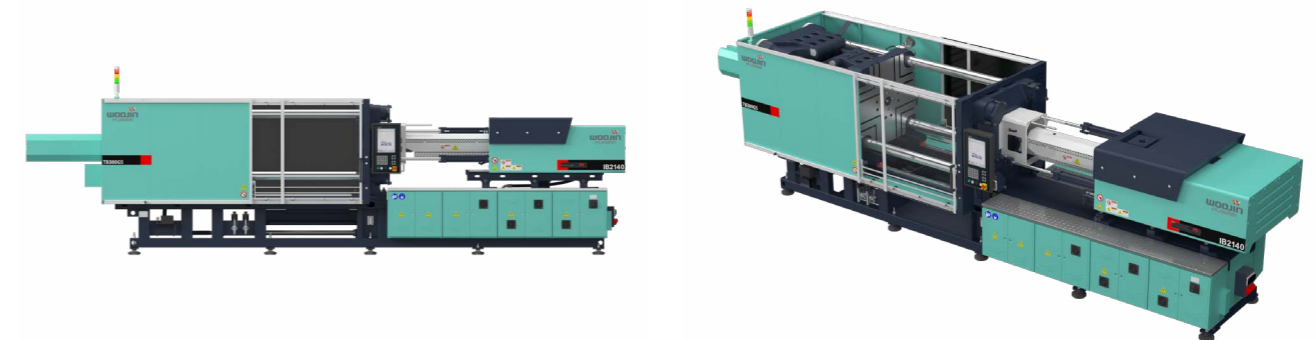

TE-G5 - Power-saving electric IMM (50~400 ton)

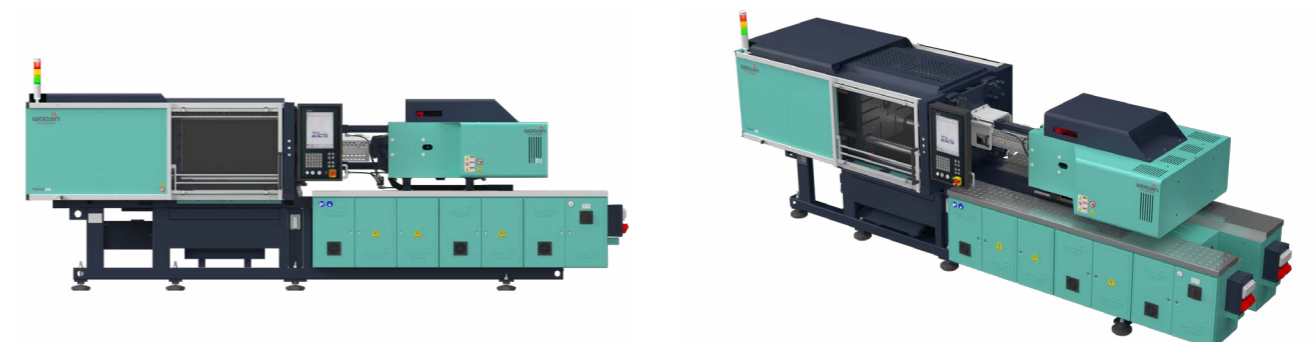

Energy Saving Solution

Linear rail system, applied on clamping & Injection unit lead to the minimized friction load. Servo motor system, calculated and selected based on the optimal machine operation condition helps customers save the energy.



Model	TE170G5	TE350G5
Product	Automotive Part	
Part Weight	58.43g	452g
1Cycle Power Consumption kWh/Kg	0.143kWh	0.112kWh
Rate (EUROMAP 60.1)	10	10

Energy Saving

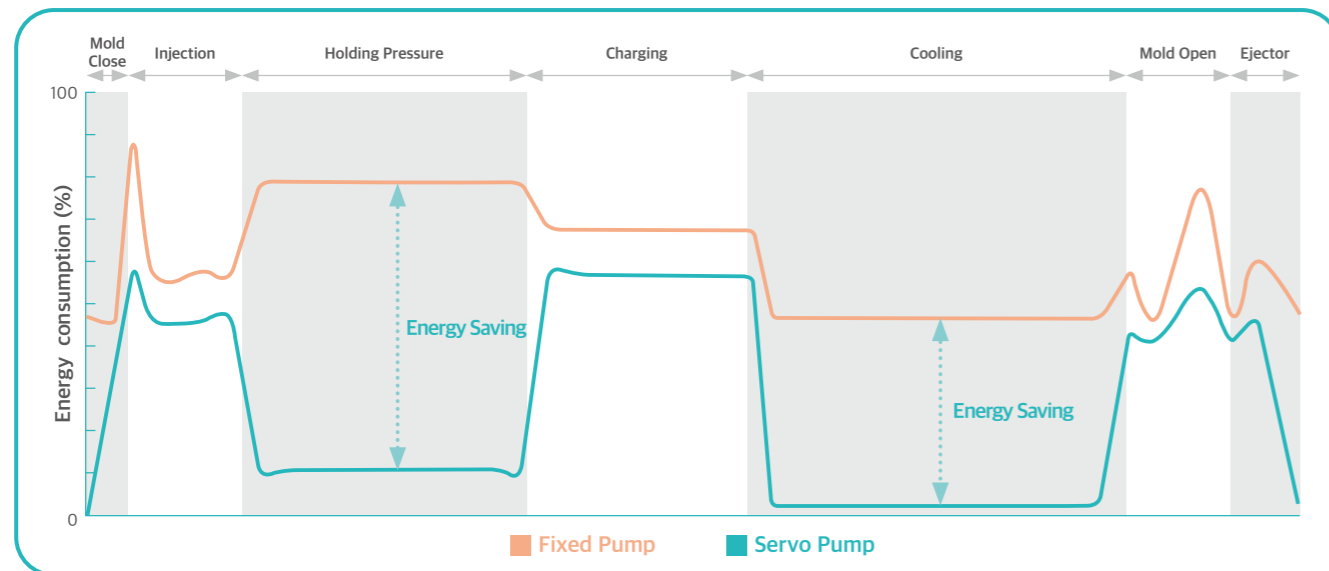

Production Process Optimization

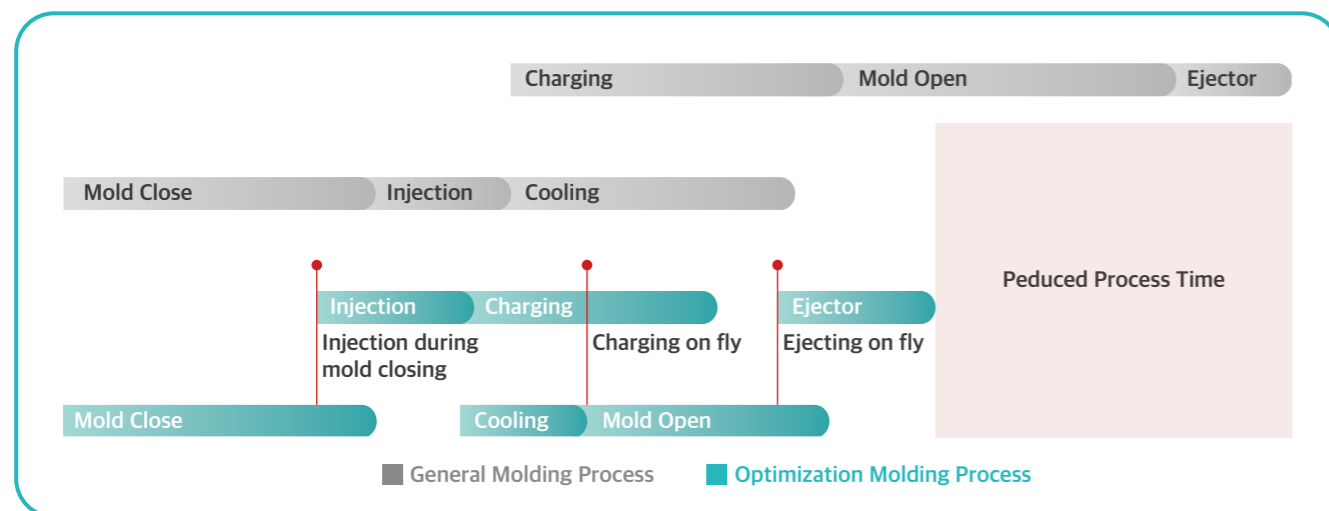

Power Consumption Reduction Effect

* Based on 1 year



Additional savings in Hydraulic oil cost



Reduce cooling water plant costs

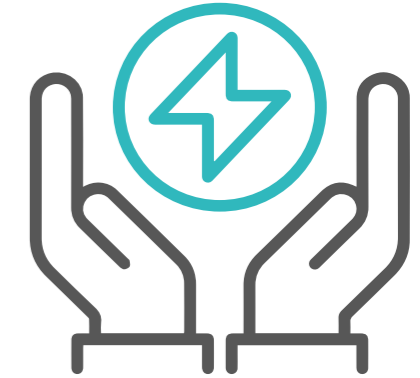

Additional savings in cooling water and electricity bills

Energy savings based on each model

* Based on daily production of 300kg

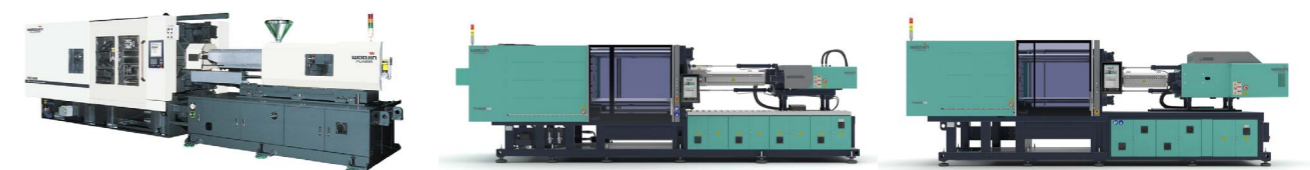

Past general hydraulics	Hybrid (TH)	Electric (TE)
191.8 kWh	95.5 kWh	73.5 kWh

TH(Hybrid): Savings of 96.3 kWh compared to general hydraulics
TE(Electric): Savings of 118.3 kWh compared to general hydraulics

Daily savings

* Korean Industrial high-voltage power A selection II rate plan standard



TH(Hybrid) saves \$7.3
TE(Electric) saves \$8.9

Electricity Savings (1 Year) * Based on TH (Hybrid) 365 days	\$2,656
Electricity Savings (1 Year) * Based on TE (Electric) 365 days	\$3,527

* This data has been generated according to the theoretical power consumption and it could differ from product specification and operation condition.

Plasticization

Woojin Plaimm Screw & Barrel Production System



Bimetalic Barrel Processing



Screw Processing

Nitrided Barrel

- Materials used from the early days of injection molding
- After deep hole processing in the base material, nitriding is performed to cure the inner diameter surface.

Bimetalic Barrel

- Produced by Woojin Plaimm with its own bimetel fusion equipment.
- All processes, such as deep hole bimetel fusion and honing, are completed in-house.
- Bimetalic Barrel produced by Korea's only injection molding machine manufacturer.
- High hardness and parent material durability compared to other companies. a long-standing

Rate	Composition	Average Hardness
Anit Wear	Fe Base + B	59±3
Aniti Wear & Corrosive	Fe Base + Cr	62±3
Extreme Anti Wear	Ni Base + W	60±3

Screw Processing

- New MCT and CNC introduction to produce more precise screws.
- Inspection of all incoming and outgoing screws.

Woojin Plaimm Screw & Barrel



Single Screw (Standard)

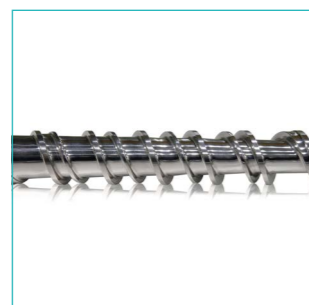

SB Screw (Option)



Mixing Screw (Option)

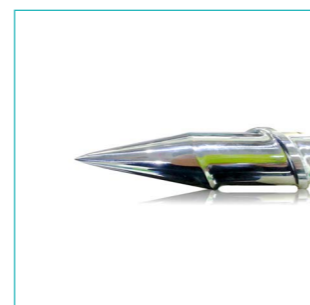

Hardened PVC Screw (Option)



Bimetalic Barrel



Nitrided Barrel



Ring Type Check Ring



Glove type Check Ring

Screw Design Analysis Program (PSI)

Operate a professional screw design analysis program to respond to various types of resins

- Continuous development of screw design with a special analysis program for screw design.
- * PSI program at Paderborn University in Germany.
- Optimized design of torque required for plasticization capacity by resin.

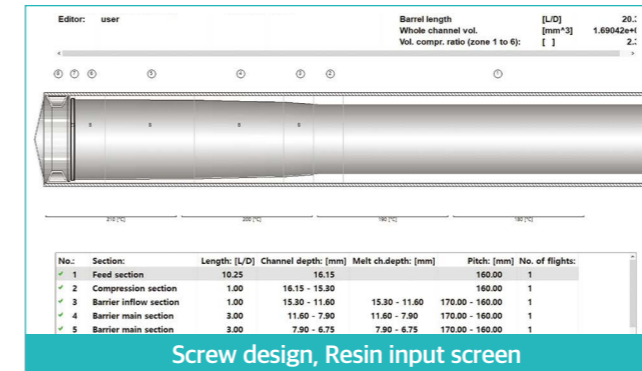

Screw design, Resin input screen

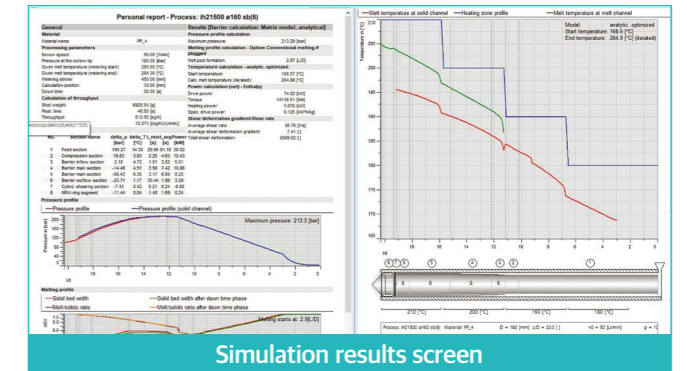

Simulation results screen

Application for plasticizing parts specifications

Barrel material	Type	Usage	Anti Wear	Corrosive
B0	Nitrided	Resin without abrasive additives	●●○○○	●●○○○
B1	Anti Wear	Resin with up to 15% of abrasive additives.	●●●○○	●●●○○
B2	Anti Wear&Corrosive	Resin with up to 30% of abrasive additives.	●●●●○	●●●●○
B4	Extreme Anti Wear&Corrosive	Resin with more than 30% of abrasive additives.	●●●●●	●●●●●

Screw material	Type	Usage	Anti Wear	Corrosive
S1	General	Resin without abrasive additives	●●○○○	●●○○○
S2	Anti Wear	Resin with up to 15% of abrasive additives.	●●●○○	●●●○○
S4	Anti Wear&Corrosive	Resin with up to 30% of abrasive additives.	●●●●○	●●●●○
S6	Extreme Anti Wear&Corrosive	Resin with more than 30% of abrasive additives.	●●●●●	●●●●●

Screw design	Type	Usage	Others
GP	General purpose	Basic general purpose, high G/F content	
GM	Mixing Screw	When using masterbatch or pigment	
G1	SB Screw	High plasticization, improved melt quality	
G3	Hardened PVC screw	Only for hardened PVC	Screw head integrated structure

Screw surface	Type	Usage	Others
HCr	Hardened chrome plating	Screw base plating	
TiN	Titanium plating (PVD)	Increased surface microhardness Improved adhesion resistance	Please inquire
CrN	Chrome plating	Increased surface microhardness Improved adhesion resistance	Please inquire
W/C	Tungsten Carbide plating	Improved anti wear & corrosive	Please inquire

Surface coating options

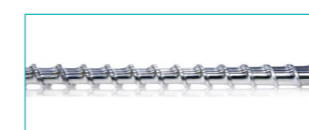

Hardened chrome plating



CrN Coating



TiN Coating



W/C Coating

Controller

IMC 710

IMC 700 (Before)

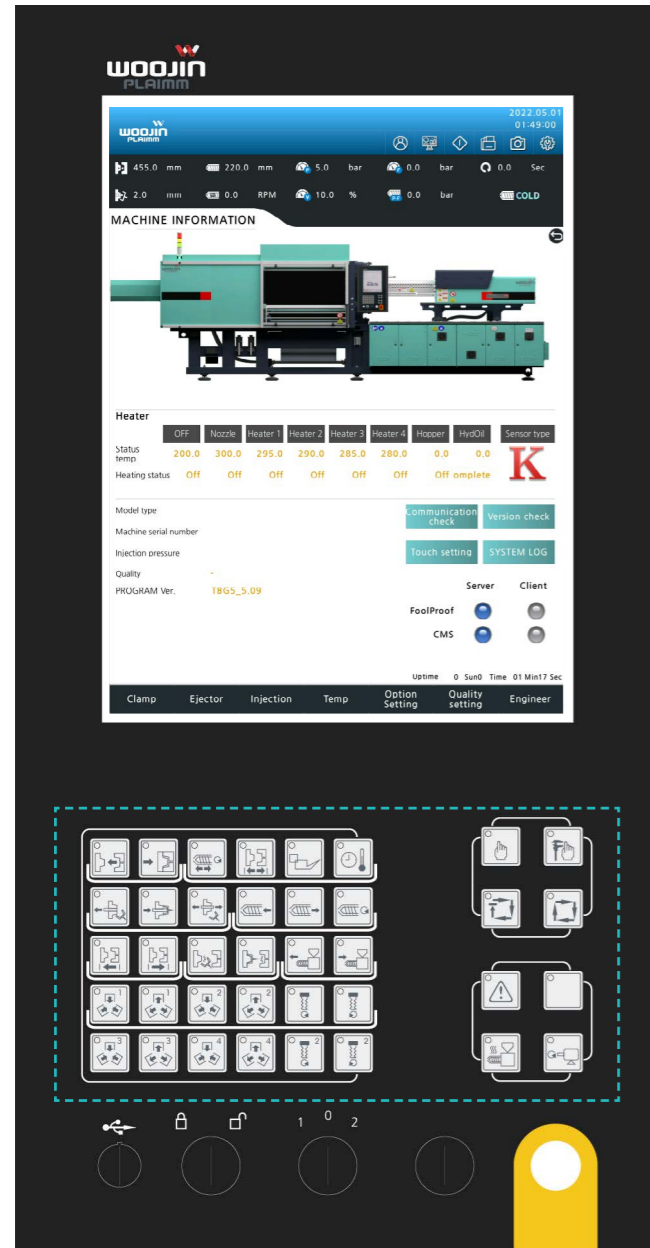

Features

- UI icon in pictogram form (thick line centered on image)
- Change existing deflate touchscreen → capacitive touchscreen
- Size (W×H×L): 311×459×56.5 (unit: mm)
- Apply and install a dedicated keypad option module due to lack of existing keypad buttons.
- * BLUECON II monitor can be applied to BLUECON II dedicated monitor

IMC 710 (New)

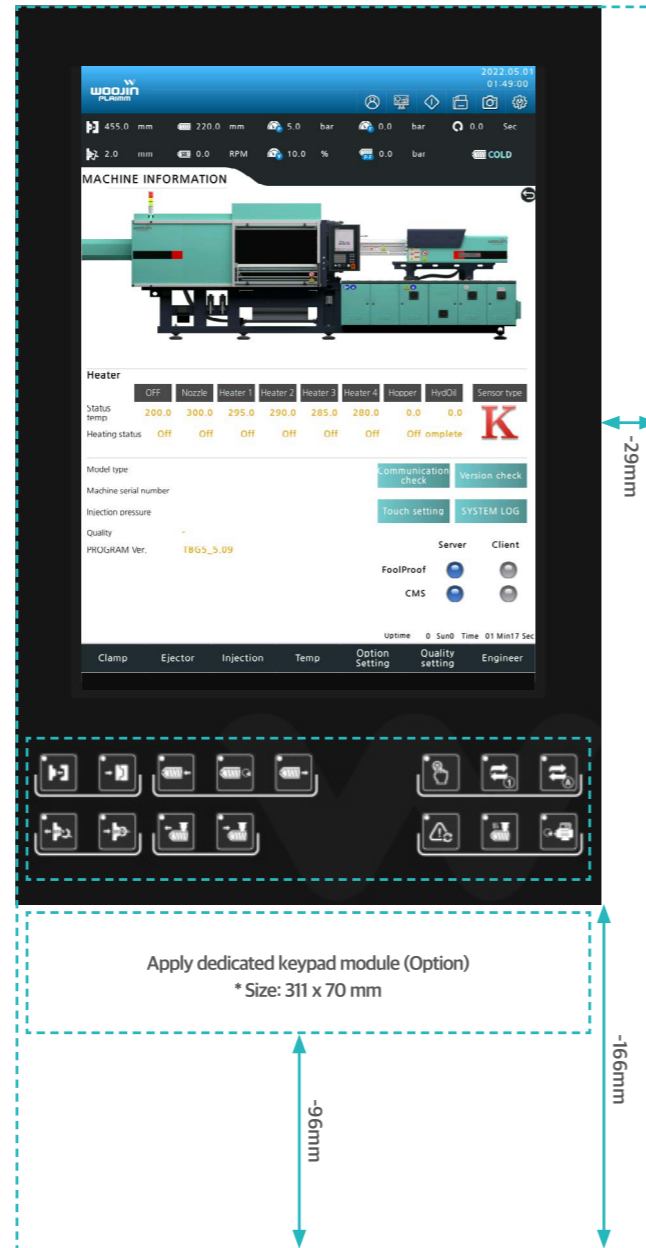

System functions

- Display: 15" (IPS LCD)
- Resolution: 768 X 1024
- Touch Screen: Capacitive
- CPU: ARM Cortex-A9 Core 11,500 DMIPS
- RAM: DDR3, 1GB
- Memory: eMMC 8GB
- IP Grade: IP65(Front), IP20(Back)
- Machine: DL-G5, TB-G5, TE-G5, VH-RG5, TE-NC, NC-G5
- Language: International Language

Main Screen

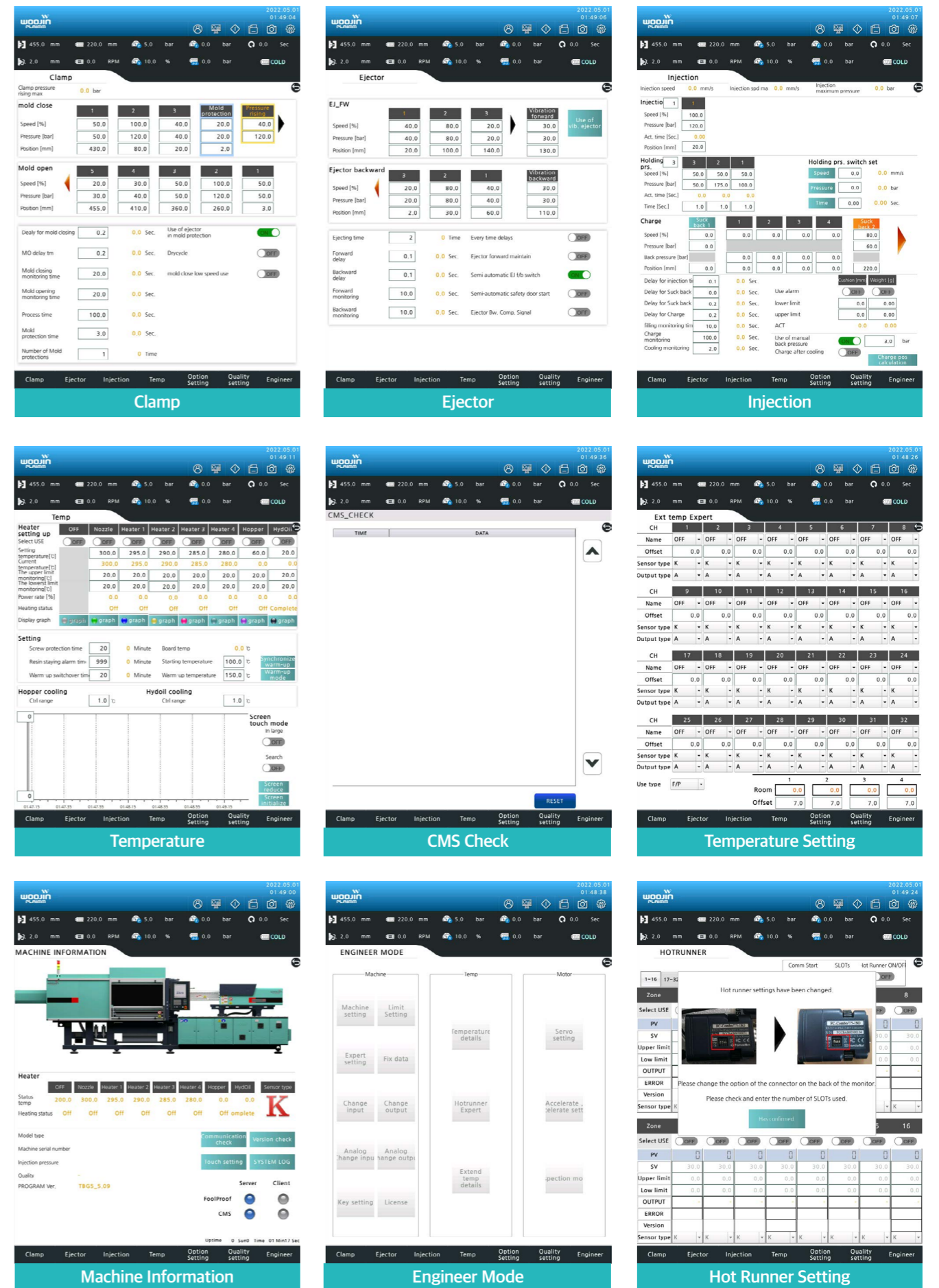

CMS

Central Monitoring System

(Option)

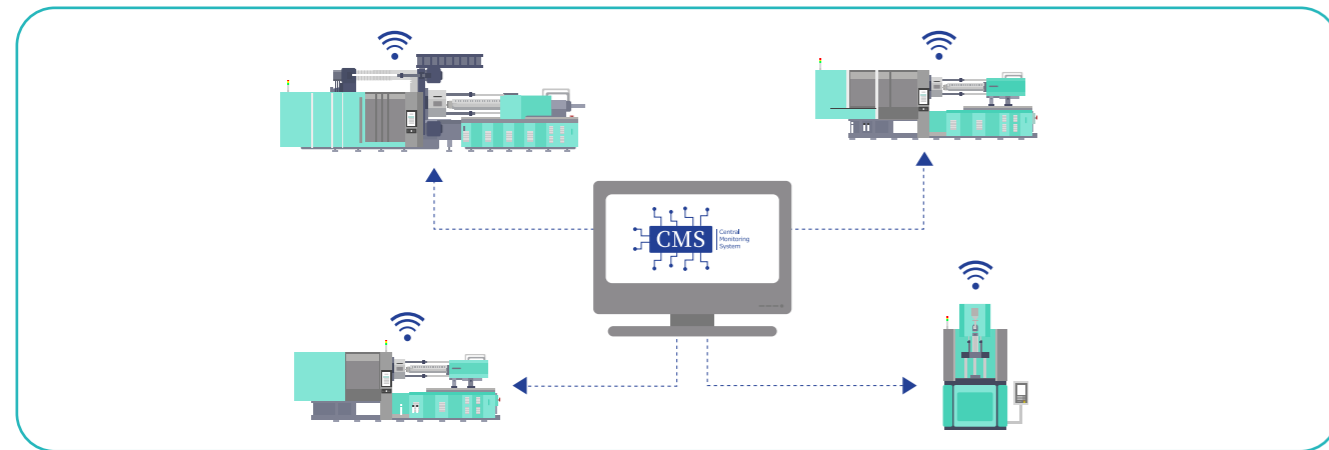

CMS (Central Monitoring System)

- 01. Collection data from injection molding machine and factory facilities.
- 02. Provision of real-time monitoring and visualization of data.
- 03. Communication synchronization function between injection molding machine and auxiliaries for factory automation.
- 04. Provision of synchronization function with higher host systems such as EMS and ERP.
- 05. Provision of remote transmission of molded data.
- 06. Provision of user manual for easy installation and maintenance.

Effectiveness

- 01. Support for productivity improvement through process control and quality control functions.
- 02. Construction of injection process DB based on universal database.
- 03. Increase efficiency of injection process management through real-time monitoring.

Software Requirement

- 01. Windows 2012 server Standard
- 02. Database: MS SQL Server 2012 Standard

Fool Proof System

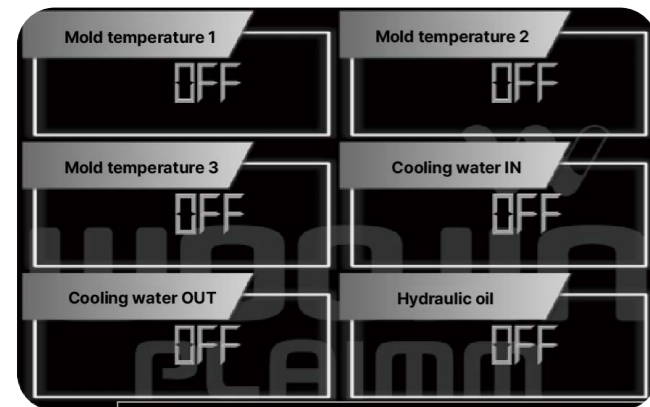

Fool Proof System

- 01. Provides communication linkage function with HMI controller monitor
- 02. Real-time injection molding machine outputs up to 12 external temperatures
- 03. Provides the ability to select the external temperature item desired by the user

Hardware

- 01. Raspberry Pi 4

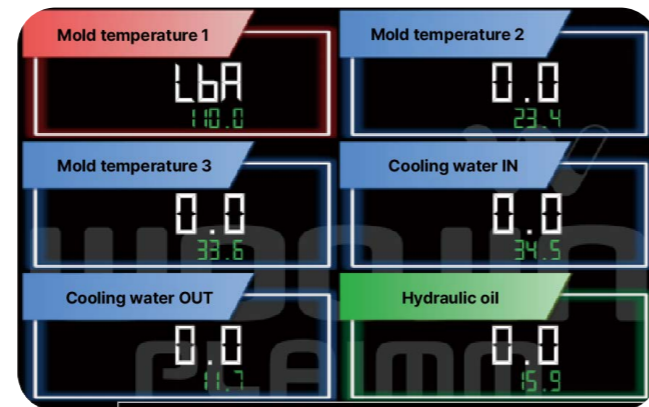

Effectiveness

- 01. You can check whether the temperature is normal through upper/lower limit settings.
- 02. External temperature can be checked for disconnection and on/off.
- 03. Daily and total production quantity can be checked for each product according to the mold

AI Smart Solution

Smart AI Injection Technology

(Option)



Smart Weight Control (PLAImm-X Weight Control)



- Solves weight deviation factors of non-drive systems, including oil temperature, resin viscosity, and check ring wear, using smart functions
- Improves quality and safety when injection molding with special materials
- Ensures uniform "injection weight" using smart functions
- Calculates injection power based on screw position

Artificial intelligence condition derivation system

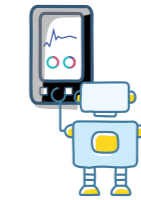

- AI-driven learning suggests optimal settings
- Useful during mold change and automatic operation
- Adjusts settings based on CMS monitoring data
- Contributes to improved productivity

Machine Test



- Automatic progress of precision inspection followed by the provision of inspection reports
- Test items: Injection and mold speed & pressure
- Test conducted based on set values, with results displayed afterward

Energy Monitoring



- Energy cost calculation for each produced part
- Comparison of energy consumption throughout the entire process
- Helps reduce power consumption

Check ring predictive maintenance

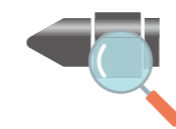

- Replacement alerts based on check ring wear data
- Automatically measures power factor during the pressure hold phase in mass production
- Reduces manufacturing costs and management labor
- Beneficial for producing GF reinforced resin products

Integrated peripheral control (EDGE Controller)



- Connects injection molding machine and peripheral devices via communication
- Allows setting changes from the controller
- Supports RS-485 communication standard

Antiflash monitoring



- The system measures the mold opening during injection and pressure hold
- Notifies the user after determining whether flash occurs

Optimization of shape force



- The system sets the optimal mold clamping force to prevent mold opening
- Reduces power consumption by applying the optimal clamping force
- Extends mold life by reducing wear on the mold

DL-G5

Power-saving two platen direct pressure IMM (450~4300 ton)

DL-G5 is power-saving two platen direct pressure injection molding machine with two fundamental principals of quality and efficiency.



YouTube

Half nut synchronous control device

- Minimize cycle time
- Fast and precise locking action

Fast and dynamic dry cycle

- 5.8 sec 1800ton EUROMAP 6

Controller (IMC 710)

- WOOJIN PLAIMM (Korea)
- 15 inch Touch Screen (IPS LCD)
- Resolution : 786 x 1024
- Supports international language

Optimized accessibility to pudging area

- Secure cleaning space
- Minimize design area

Ball bearing type linear guide

- Reduce friction resistance
- Improved forming precision

Injection unit

- Apply two axis injection rod, based on high rigidity
- Single screw (Standard)
- Improved injection response
- Back pressure closed-loop control improves injection reproducibility and responsiveness

Hydraulic unit

- High efficiency servo pump system
- Application of Parker valve and Dorninger hydraulic block
- Independent filter & cooling system
- Improved pump cover design: noise reduction

Integral cabinet including inverter

- Reduce machine installation area
- Improved convenience of maintenance management

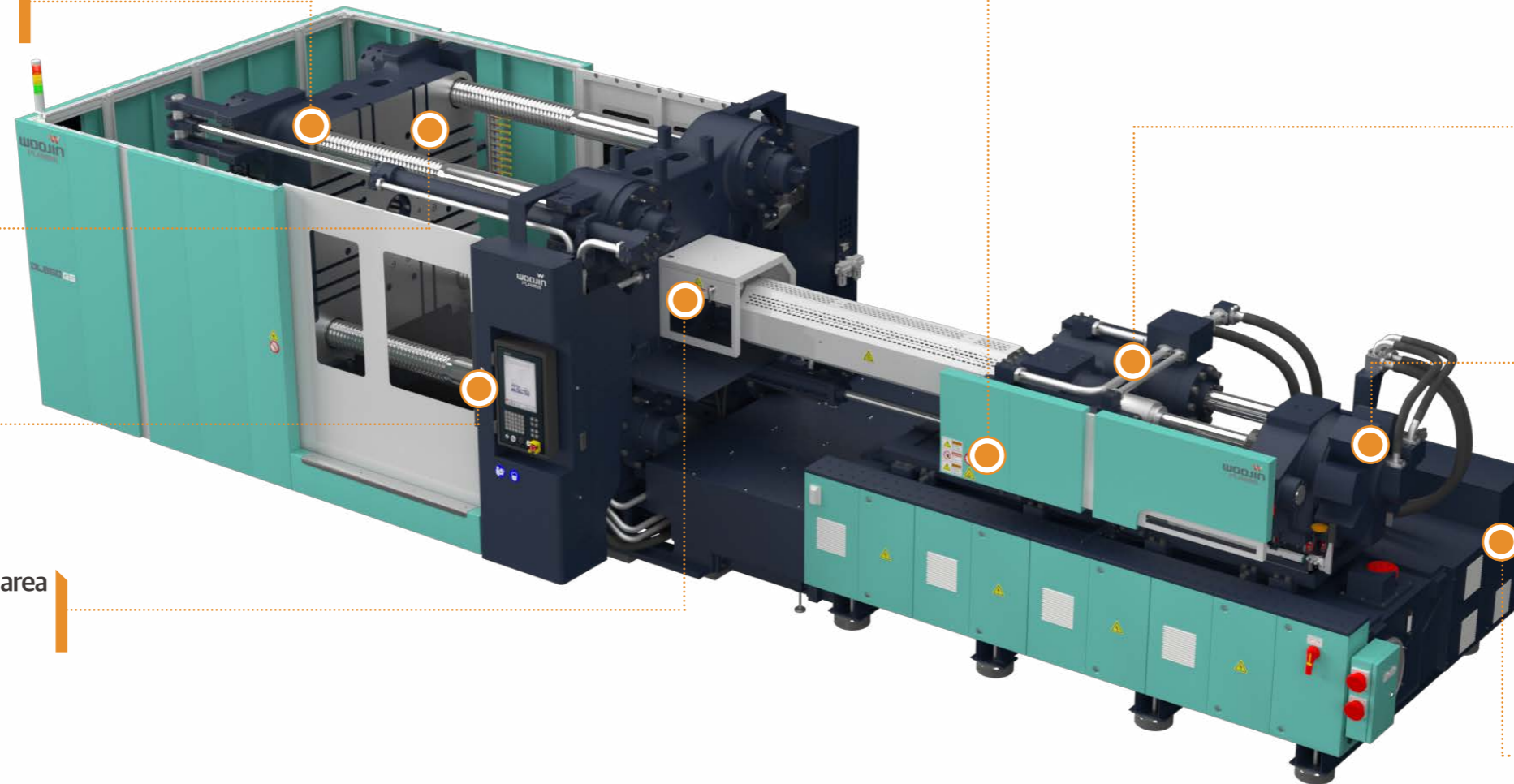

High-quality implementation with top-of-the-line performance brand components



Controller



Servo Motor



Drive



Hydraulic Block



Oil Filter



Hydraulic Valve



Hydraulic Pump



Oil Cooler

Clamping Unit

01. X type designed platen

- Simple casting reference point for high platen stiffness
- Separable booster cylinder applied to stationary mold platen and optimized for use with retractable tie bar.

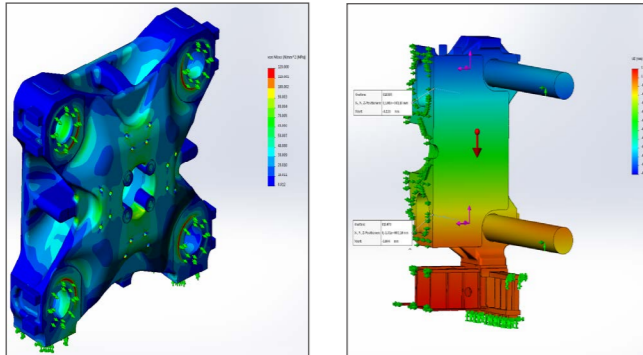

02. Automatic tie-bar retraction (Option)

- Easy & prompt big sized mold installation
- Maximizes available space and ideal for installing large molds
- Applicable to the entire tone range when applying VER.2



03. Fast moving cylinder

- Bilateral symmetry designed for preventing platen's deformation during low pressure mold closing stage.
- Improved structure of moving cylinder for smooth, high-speed movement.

04. Position measurement system

- Tie bar position controlled by stroke transducer.

05. High speed synchronous half nut locking system

- Double acting half nut design for reducing cycle time and fast locking and unlocking.

06. New design for optimized force distribution of tie bar

- Newly designed force distribution of tie bar for improved durability

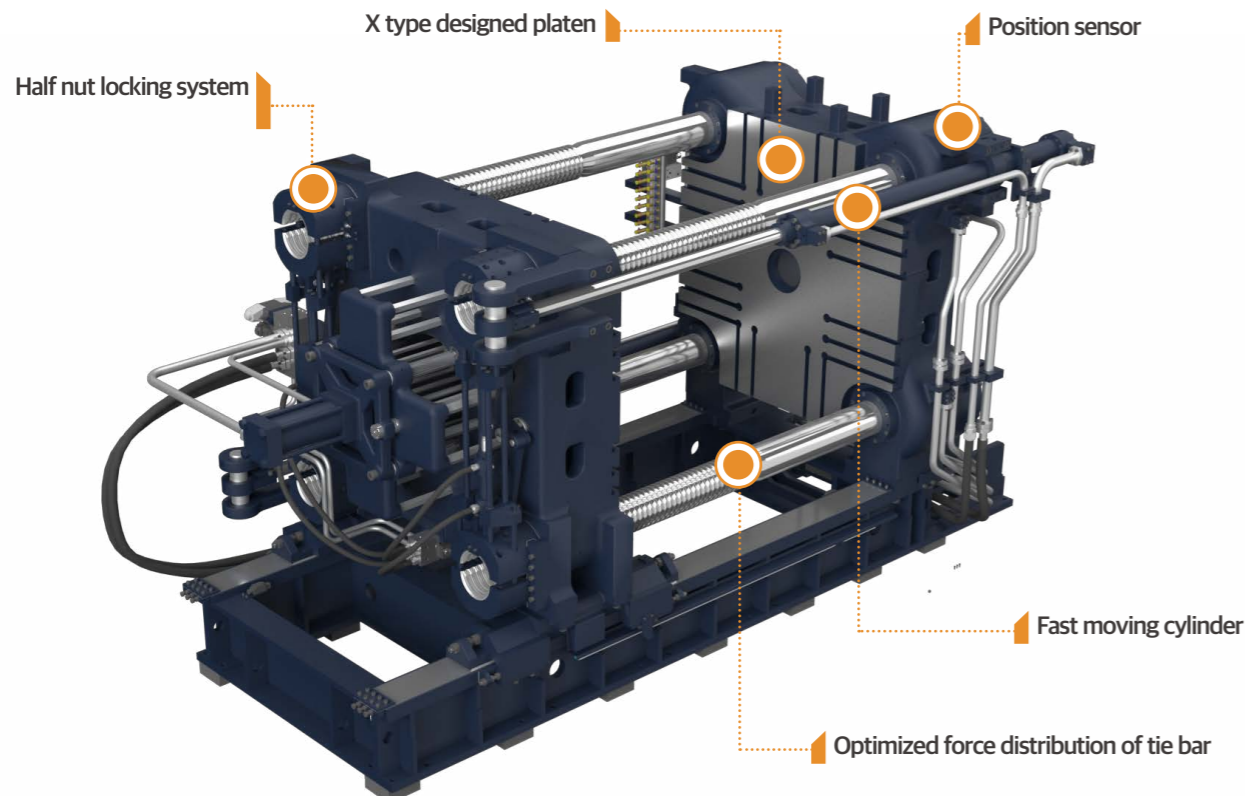

Injection Unit

* Automatic swiveling function may not be applicable when not using standard injection unit.

01. Closed-loop back pressure control

- A proportional valve control circuit uses pressure sensor feedback to provide responsive

03. Linear guided injection unit

- Linear guide provides stable, low-friction rails to support precision control of the screw

05. Automatic swivelling function of injection unit

- The injection device can be swivelled with a simple operation, making screw and barrel replacement convenient. (IH2800~IH11900)

07. PID controlled heating bands

- Minimize the deviation of temperature by constant monitoring & feedback after setting parameters
- Avoid resin carbonization & poor material quality by synchronous barrel heating

02. Integrated designed inverter box cover

- Improved space availability through integrated inverter box

04. Dual cylinder in-line screw injection unit

- Featuring stable & powerful injection capability

06. Pump cover design for low noise

- Low noise & improved space availability by enhanced pump cover design
- Easy to remove the covers by one person

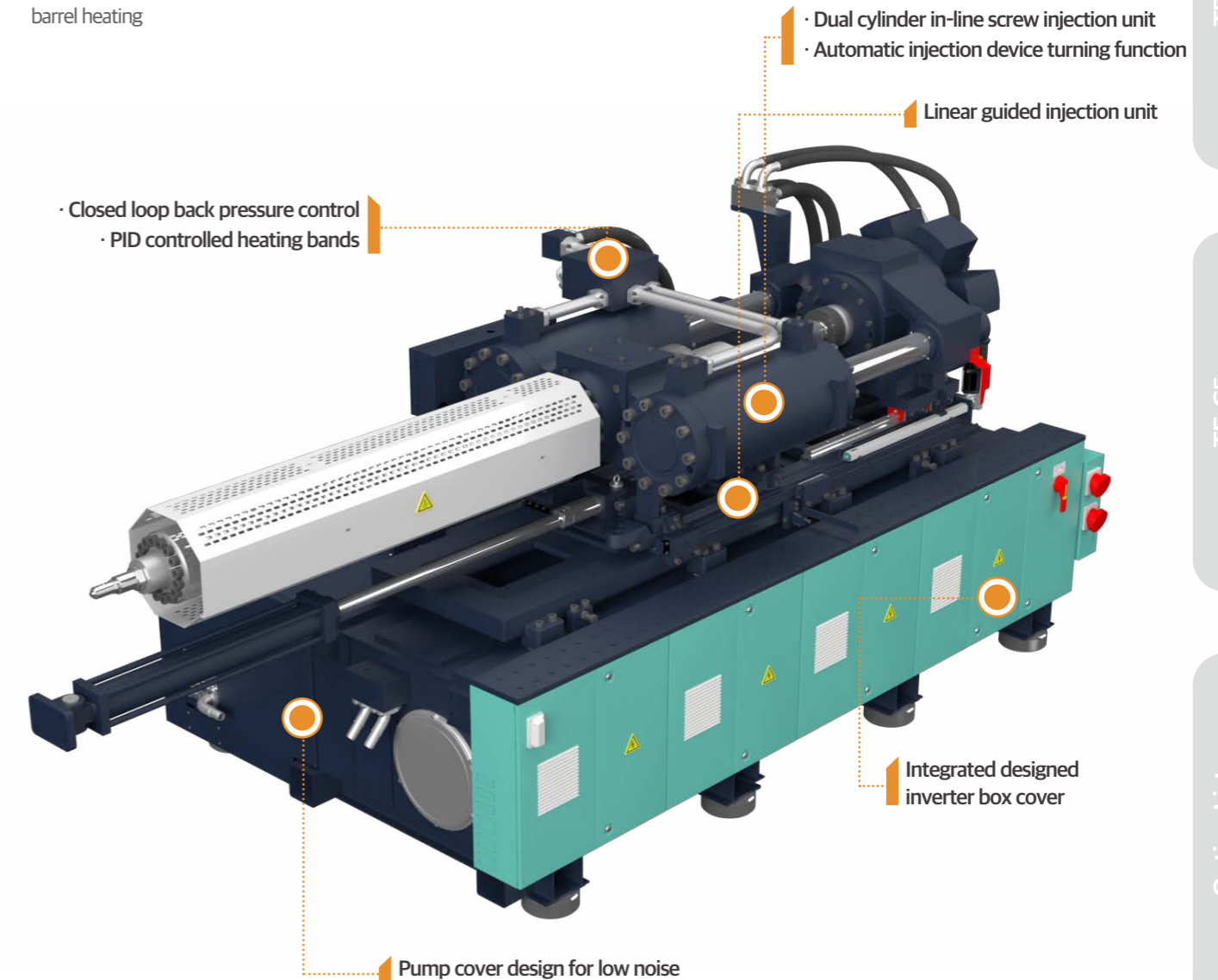

Hydraulic Unit

01. Air breather

- Allows air in/out of the oil tank as oil volume changes due to flow
- It maintains atmospheric air pressure and eliminate dust & moisture, steam in the air

02. Oil pipe & tank

- Seamless pipe design is without welds, preventing oil leakage
- Polymer coating inside the oil tank to prevent moisture buildup

03. Independent cooling & filtering system

- It contributes maintaining cleanness of hydraulic oil and its temperature and extend the oil's replacement time as well as improvement of hydraulic parts.

04. Servo pump system

- Reduce power consumption & cooling water by minimizing motor shaft's rotation through application of servo motive technology

05. Special painting & coating on hydraulic manifold

- Improved inner cleanness and anticorrosion

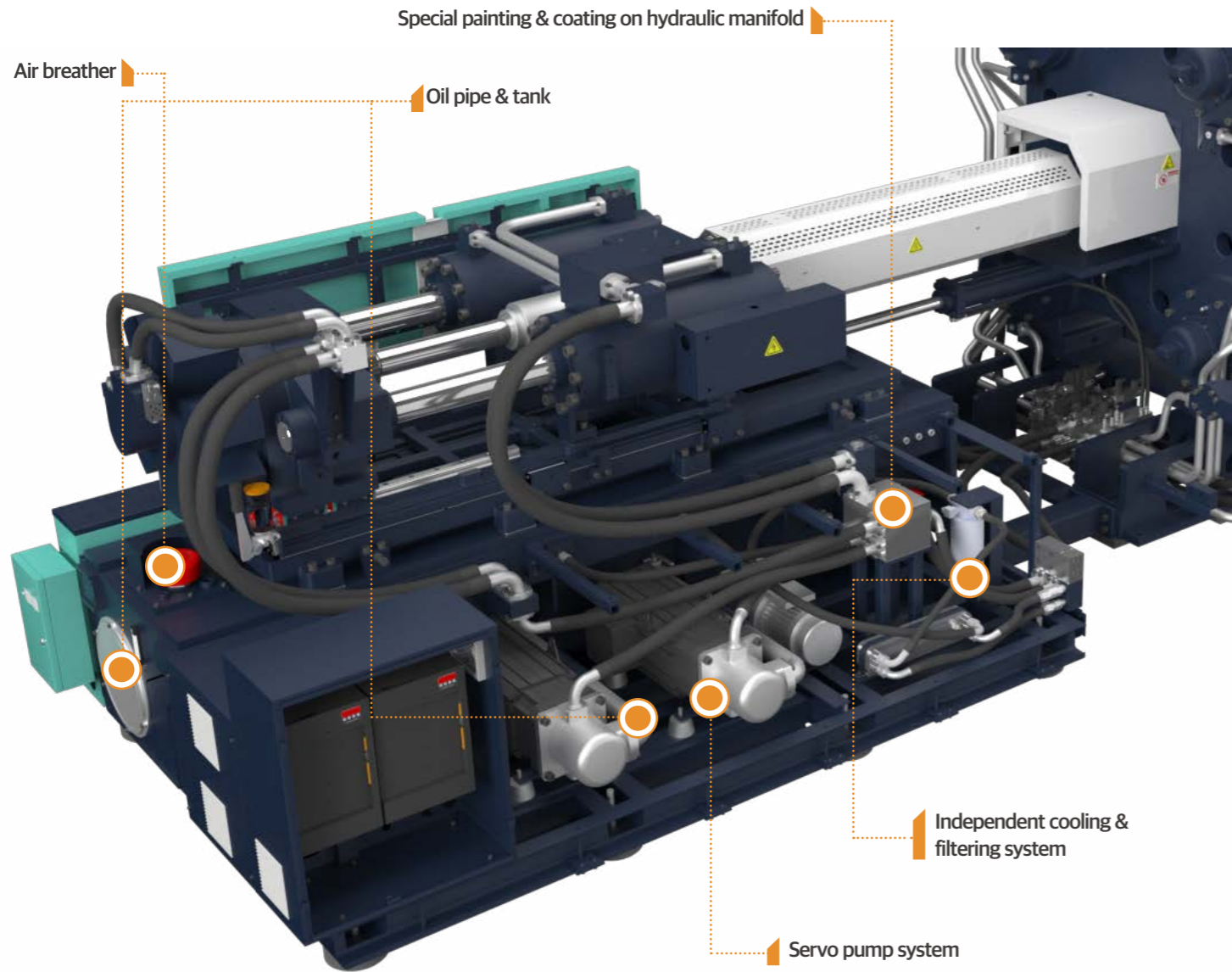

Specification DL-G5(Ver.1)

Model	DL450G5			DL550G5			DL650G5			
	IH2800			IH4200			IH5900			
Injection Unit										
Screw & Barrel type		O	A	B	O	A	B	O	A	B
Screw diameter	mm	65	70	80	70	80	90	80	90	105
Injection pressure	kg/cm ²	2191	1889	1446	2465	1887	1491	2386	1885	1385
	Mpa	215	185	142	242	185	146	234	185	136
Theoretical injection volume	cm ³	1278	1482	1935	1693	2212	2799	2488	3149	4286
Shot weight (PS)	g	1177	1365	1783	1560	2038	2579	2293	2902	3950
Injection rate	cm ³ /s	407	472	617	461	602	762	603	763	1039
Screw stroke	mm	385			440			495		
Injection speed	mm/s	123			120			120		
Plasticizing capacity (PS)	kg/h	207	252	358	231	328	449	298	408	619
Screw rotation speed	rpm	180			165			150		
Clamping Unit										
Clamping force	ton(kN)	450(4413)			550(5394)			650(6374)		
Mold opening force	ton(kN)	34(331)			41(405)			49(478)		
Distance between tie-bar (H×V)	mm	860 x 810			915 x 915			1010 x 1010		
Platen dimension (H×V)	mm	1240 x 1190			1330 x 1330			1460 x 1460		
Max. Daylight	mm	1450			1600			1800		
Min. mold height	mm	350			400			450		
Max. mold height	mm	800			950			1100		
Ejector force	ton(kN)	11.1(108.9)			16.6(162.8)			19.8(194.2)		
Ejector stroke	mm	200			220			250		
Max. mold weight (Fixed / Moving / Total)	ton	3.5 / 3.5 / 5			4 / 4 / 6			5.5 / 5.5 / 8		
General										
Heater capacity	kW	18.4	20.6	24.1	23.0	26.7	30.7	29.4	33.6	39.3
Motor capacity	kW	78.0			88.0			106.0		
Total electric power capacity	kW	96.4	98.6	102.1	111.0	114.7	118.7	135.4	139.6	145.3
Hydraulic oil tank capacity	L	800			1050			1350		
Machine weight (Clamping+Injection)	ton	19(13.5+5.5)			26(17+9)			32(21.5+10.5)		
Machine dimension (L×W×H)	m	7.5 x 2.4 x 2.1			7.7 x 2.8 x 2.2			8.2 x 2.9 x 2.3		
Cooling water consumption	L/min	130			130			130		

DL-G5
450~4300 ton

TB-G5
90~880 ton

TE-G5
50~400 ton

Option List
DL-G5 / TB-G5 / TE-G5

DL-G5
450~4300 ton

TB-G5
90~880 ton

TE-G5
50~400 ton

Option List
DL-G5 / TB-G5 / TE-G5

Specification DL-G5(Ver.1)

Model	DL850G5			DL1050G5			DL1300G5		DL1600G5		DL1800G5		
	IH8800			IH8800			IH11900		IH11900		IH15300		
Injection Unit													
Screw & Barrel type		O	A	B	O	A	B	A	B	A	B	A	B
Screw diameter	mm	95	105	115	95	105	115	115	125	115	125	125	140
Injection pressure	kg/cm ²	2145	1756	1464	2145	1756	1464	1809	1531	1809	1531	1814	1446
	Mpa	210	172	144	210	172	144	177	150	177	150	178	142
Theoretical injection volume	cm ³	4111	5022	6024	4111	5022	6024	6544	7731	6544	7731	8430	10580
Shot weight (PS)	g	3788	4628	5551	3788	4628	5551	6030	7124	6030	7124	7768	9749
Injection rate	cm ³ /s	852	1041	1248	852	1041	1248	1249	1475	1249	1475	1296	1626
Screw stroke	mm	580			580			630		630		690	
Injection speed	mm/s	120			120			120		120		106	
Plasticizing capacity (PS)	kg/h	393	515	660	393	515	660	607	757	607	757	692	939
Screw rotation speed	rpm	125			125			115		115		105	
Clamping Unit													
Clamping force	ton(kN)	850(8336)			1050(10297)			1300(12749)		1600(15691)		1800(17652)	
Mold opening force	ton(kN)	64(625)			79(772)			98(956)		120(1177)		135(1324)	
Distance between tie-bar (H×V)	mm	1110 x 1110			1410 x 1110			1410 x 1410		1570 x 1285		1810 x 1610	
Platen dimension (H×V)	mm	1610 x 1610			1950 x 1650			1950 x 1950		2160 x 1925		2450 x 2180	
Max. Daylight	mm	2300			2400			2500		3200		3200	
Min. mold height	mm	500			600			700		700		700	
Max. mold height	mm	1200			1200			1200		1500		1600	
Ejector force	ton(kN)	26.9 (263.8)			26.9(263.8)			34.4(337.3)		34.4(337.3)		44.5(436.4)	
Ejector stroke	mm	250			250			300		300		300	
Max. mold weight (Fixed / Moving / Total)	ton	7 / 7 / 10.5			8.5 / 8.5 / 13			12 / 12 / 17		14 / 14 / 21		16 / 16 / 24	
General													
Heater capacity	kW	39.7	44.7	49.4	39.7	44.7	49.4	54.7	58.1	54.7	58.1	61.6	70.8
Motor capacity	kW	134.0			134.0			173.0		173.0		173.0	
Total electric power capacity	kW	173.7	178.7	183.4	173.7	178.7	183.4	227.7	231.1	227.7	231.1	234.6	243.8
Hydraulic oil tank capacity	L	1350			1350			1700		1700		1700	
Machine weight (Clamping+Injection)	ton	41(29+12)			50(37.5+12.5)			67(50+17)		77(60+17)		89(70+19)	
Machine dimension (L×W×H)	m	9.6 x 3.2 x 2.5			10 x 3.5 x 2.5			10.8 x 3.6 x 2.9		11.6 x 3.8 x 2.9		12.2 x 4.1 x 3.4	
Cooling water consumption	L/min	180			180			180		180		180	

01. Theoretical injection volume: cross section of screw*screw stroke.
 02. The minimum mold size should be more than 70% of tie-bar distance.
 03. The specifications might be changed without any prior notice.
 04. The metering distance is recommended in the range of 1 to 3 times of screw diameter.

Model	DL2300G5		DL2700G5		DL3300G5		DL4300G5				
	IH15300		IH21500		IH31700		IH66300		IH100200		
Injection Unit											
Screw & Barrel type		A	B	A	B	A	B	A	B	A	B
Screw diameter	mm	125	140	140	160	160	180	200	220	230	250
Injection pressure	kg/cm ²	1814	1446	1816	1391	1823	1440	1744	1441	1798	1522
	Mpa	178	142	178	136	179	141	171	141	172	146
Theoretical injection volume	cm ³	8430	10580	11850	15480	17690	22390	38013	45996	57128	67495
Shot weight (PS)	g	7768	9749	10920	14265	16301	20632	35029	42385	52643	62197
Injection rate	cm ³ /s	1296	1626	1547	2020	1719	2176	2299	2781	2918	3448
Screw stroke	mm	690		770		880		1210		1375	
Injection speed	mm/s	106		100		85		73		70	
Plasticizing capacity (PS)	kg/h	692	939	850	1218	1026	1413	1533	1841	1318	1452
Screw rotation speed	rpm	105		95		80		65		55	
Clamping Unit											
Clamping force	ton(kN)	2300(22555)		2700(26478)		3300(32362)		4300(42169)			
Mold opening force	ton(kN)	173(1692)		203(1986)		248(2427)		323(3163)			
Distance between tie-bar (H×V)	mm	2020 x 1610		2180 x 1760		2260 x 1810		2350 x 2050			
Platen dimension (H×V)	mm	2600 x 2250		3030 x 2610		3140 x 2660		3400 x 3100			
Max. Daylight	mm	3600		3900		4000		4400			
Min. mold height	mm	800		900		1100		1100			
Max. mold height	mm	1700		2000		2000		2200			
Ejector force	ton(kN)	44.5(436.4)		67.8(664.9)		67.8(664.9)		67.8(664.9)			
Ejector stroke	mm	300		350		350		400			
Max. mold weight (Fixed / Moving / Total)	ton	41 / 41 / 62		50 / 50 / 75		56 / 56 / 85		66 / 66 / 100			
General											
Heater capacity	kW	61.6	70.8	78.4	93.1	106.3	123.4	157.7	184.5	220.0	240.5
Motor capacity	kW	178.0		229.8		229.8		335.0		402.0	
Total electric power capacity	kW	239.6	248.8	308.2	322.9	336.1	353.2	492.7	519.5	622.0	642.5
Hydraulic oil tank capacity	L	1700		2000		3000		5000		5500	
Machine weight (Clamping+Injection)	ton	115(96+19)		143(121+22)		180(149+31)		229(191+38)		241(191+50)	
Machine dimension (L×W×H)	m	12.9 x 4.5 x 3.4		14.7 x 4.7 x 3.8		16.5 x 5 x 3.7		20.6 x 5.4 x 4.4		20.6 x 5.4 x 4.4	
Cooling water consumption	L/min	180		240		240		240		240	

DL-G5
450~4300 ton

TB-G5
90~880 ton

TE-G5
50~400 ton

Option List
DL-G5 / TB-G5 / TE-G5

DL-G5
450~4300 ton

TB-G5
90~880 ton

TE-G5
50~400 ton

Option List
DL-G5 / TB-G5 / TE-G5

Platen Dimension

DL-G5(Ver.1)

단위: mm

DL450G5 (A: 500 / B: 250) DL550G5 (A: 560 / B: 280)
DL650G5 (A: 650 / B: 400)

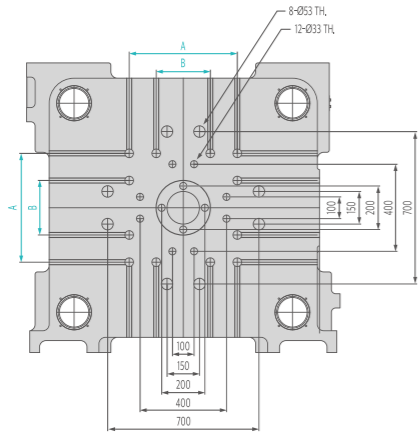

DL850A5 (A: 650) DL1050A5 (A: 750)

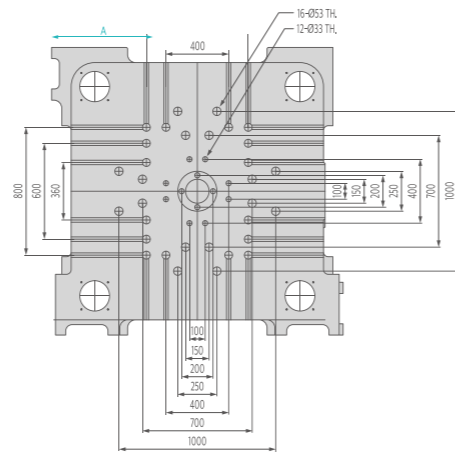

DL1300G5 (A: 525 / B: 350) DL1600G5 (A: 450 / B: 325)

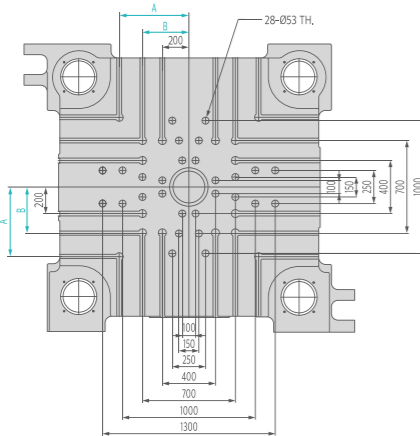

DL1800G5 (A: 850) DL2300G5 (A: 900)
DL2700G5 (A: 1115) DL3300G5 (A: 1165)

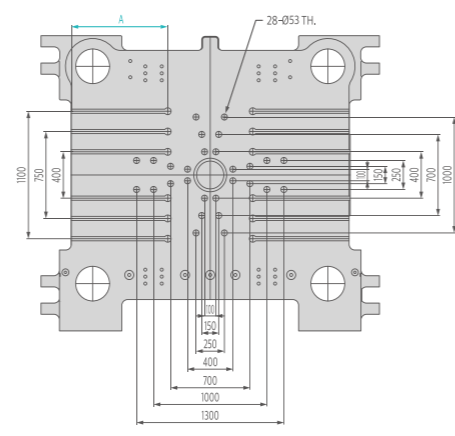

DL4300G5

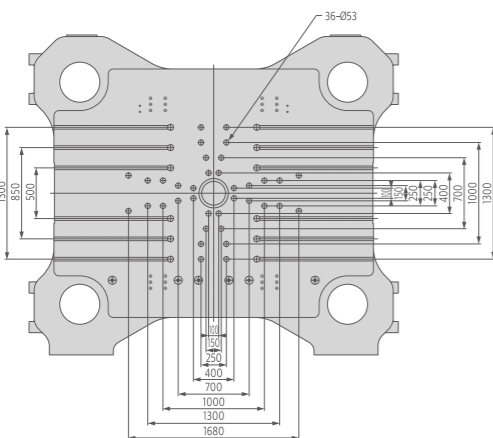

* The images and specifications might be changed without any prior notice.

Machine Dimension

DL-G5(Ver.1)

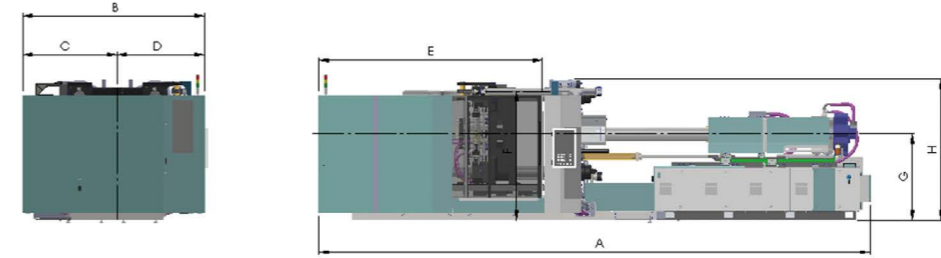

Machine Dimension

단위: mm	A	B	C	D	E	F	G	H
DL450G5	7501	2340	1225	1115	2893	1965	1410	2105
DL550G5	7677	2807	1499	1308	3009	2033	1410	2190
DL650G5	8206	2909	1551	1358	3328	2135	1450	2305
DL850G5	9566	3157	1639	1518	3919	2245	1490	2435
DL1050G5	9952	3499	1789	1710	4305	2265	1490	2475
DL1300G5	10726	3545	1800	1745	4513	2661	1725	2901
DL1600G5	11527	3775	1915	1860	5238	2645	1725	2905
DL1800G5	12146	4099	2097	2002	5530	3028	1969	3310
DL2300G5	12974	4423	2284	2139	6083	3065	1969	3101
DL2700G5	14680	4623	2394	2229	6767	3344	2116	3771
DL3300G5	16437	4973	2599	2374	6917	3608	2324	3664
DL4300G5	20580	5323	2824	2499	7137	3768	2568	4360

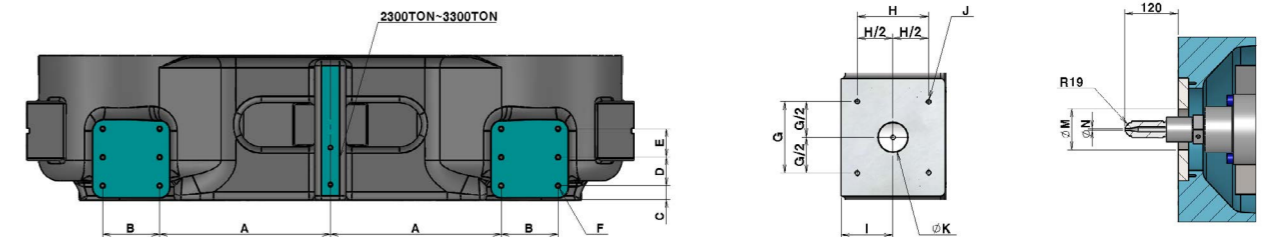

단위: mm	Robot installation position dimension						Hopper installation position dimension				Nozzle dimension		
	A	B	C	D	E	F	G	H	I	J	ØK	ØM	ØN
DL450G5	210	-	105	185	-	4-M20	165	165	120	4-M12	68	100	4
DL550G5	195	-	105	245	-	4-M20	165	165	130	4-M12	78	100	5
DL650G5	235	-	110	265	-	4-M24	165	165	140	4-M12	88	100	5
DL850G5	235	-	115	330	-	4-M24	165	165	170	4-M12	103	100	6
DL1050G5	335	-	125	375	-	4-M30	165	165	170	4-M12	103	100	6
DL1300G5	560	280	70	140	140	12-M24	280	200	190	4-M16	113	120	6
DL1600G5	560	280	70	140	140	12-M24	280	200	190	4-M16	113	120	6
DL1800G5	840	280	70	140	140	12-M24	280	200	200	4-M16	123	120	7
DL2300G5	500	-	140	575	-	6-M24	280	200	200	4-M16	123	120	7
DL2700G5	625	-	155	600	-	6-M36	280	200	220	4-M16	138	120	7
DL3300G5	625	-	150	630	-	6-M36	280	200	240	4-M16	158	120	8
DL4300G5	625	-	150	630	-	6-M36	280	200	218	4-M16	172	120	8

* The images and specifications might be changed without any prior notice.

Specification

DL-G5(Ver.2)

Model	DL500G5			DL600G5			DL700G5			
	IH2800			IH4200			IH5900			
Injection Unit										
Screw & Barrel type		O	A	B	O	A	B	O	A	B
Screw diameter	mm	65	70	80	70	80	90	80	90	105
Injection pressure	kg/cm ²	2191	1889	1446	2465	1887	1491	2386	1885	1385
	Mpa	215	185	142	242	185	146	234	185	136
Theoretical injection volume	cm ³	1278	1482	1935	1693	2212	2799	2488	3149	4286
Shot weight (PS)	g	1177	1365	1783	1560	2038	2579	2293	2902	3950
Injection rate	cm ³ /s	407	472	617	461	602	762	603	763	1039
Screw stroke	mm	385			440			495		
Injection speed	mm/s	123			120			120		
Plasticizing capacity (PS)	kg/h	207	252	358	231	328	449	298	408	619
	rpm	180			165			150		
Clamping Unit										
Clamping force	ton(kN)	500(4903)			600(5884)			700(6865)		
Mold opening force	ton(kN)	38(368)			45(441)			53(515)		
Distance between tie-bar (H×V)	mm	920 x 830			1040 x 910			1110 x 1010		
Platen dimension (H×V)	mm	1280 x 1260			1430 x 1370			1520 x 1490		
Max. Daylight	mm	1650			1750			1850		
Min. mold height	mm	350			400			450		
Max. mold height	mm	900			950			950		
Ejector force	ton(kN)	11.1(108.9)			16.6(162.8)			19.8(194.2)		
Ejector stroke	mm	200			220			250		
Max. mold weight (Fixed / Moving / Total)	ton	5.3 / 5.3 / 8			6.7 / 6.7 / 10			7.3 / 7.3 / 11		
General										
Heater capacity	kW	18.4	20.6	24.1	23.0	26.7	30.7	29.4	33.6	39.3
Motor capacity	kW	83.0			100.0			111.0		
Total electric power capacity	kW	101.4	103.6	107.1	123.0	126.7	130.7	140.4	144.6	150.3
Hydraulic oil tank capacity	L	800			1050			1350		
Machine weight (Clamping+Injection)	ton	19(13.5+5.5)			26(17+9)			32(21.5+10.5)		
Machine dimension (L×W×H)	m	7.6 x 2.7 x 2.2			7.9 x 2.9 x 2.2			8.3 x 3.1 x 2.4		
Cooling water consumption	L/min	130			130			130		

01. Theoretical injection volume: cross section of screw*screw stroke.
02. The minimum mold size should be more than 70% of tie-bar distance.

03. The specifications might be changed without any prior notice.
04. The metering distance is recommended in the range of 1 to 3 times of screw diameter.

Model	DL900G5			DL1100G5			DL1350G5		DL1850G5		
	IH8800			IH8800			IH11900		IH15300		
Injection Unit											
Screw & Barrel type		O	A	B	O	A	B	A	B	A	B
Screw diameter	mm	95	105	115	95	105	115	115	125	125	140
Injection pressure	kg/cm ²	2145	1756	1464	2145	1756	1464	1809	1531	1814	1446
	Mpa	210	172	144	210	172	144	177	150	178	142
Theoretical injection volume	cm ³	4111	5022	6024	4111	5022	6024	6544	7731	8430	10580
Shot weight (PS)	g	3788	4628	5551	3788	4628	5551	6030	7124	7768	9749
Injection rate	cm ³ /s	852	1041	1248	852	1041	1248	1249	1475	1296	1626
Screw stroke	mm	580			580			630		690	
Injection speed	mm/s	120			120			120		106	
Plasticizing capacity (PS)	kg/h	393	515	660	393	515	660	607	757	692	939
	rpm	125			125			115		105	
Clamping Unit											
Clamping force	ton(kN)	900(8826)			1100(10787)			1300(12749)		1800(17652)	
Mold opening force	ton(kN)	68(662)			83(809)			98(956)		135(1324)	
Distance between tie-bar (H×V)	mm	1200 x 1120			1420 x 1170			1580 x 1280		1850 x 1610	
Platen dimension (H×V)	mm	1720 x 1610			1870 x 1820			2230 x 1990		2450 x 2200	
Max. Daylight	mm	2100			2400			3050		3400	
Min. mold height	mm	500			600			700		700	
Max. mold height	mm	1100			1200			1400		1600	
Ejector force	ton(kN)	26.9(263.8)			26.9(263.8)			34.4(337.3)		44.5(436.4)	
Ejector stroke	mm	250			250			300		300	
Max. mold weight (Fixed / Moving / Total)	ton	8.6 / 8.6 / 13			14 / 14 / 21			20 / 20 / 30		30 / 30 / 45	
General											
Heater capacity	kW	39.7	44.7	49.4	39.7	44.7	49.4	54.7	58.1	61.6	70.8
Motor capacity	kW	134.0			134.0			178.0		178.0	
Total electric power capacity	kW	173.7	178.7	183.4	173.7	178.7	183.4	232.7	236.1	239.6	248.8
Hydraulic oil tank capacity	L	1350			1350			1700		1700	
Machine weight (Clamping+Injection)	ton	41(29+12)			50(37.5+12.5)			72(55+17)		89(70+19)	
Machine dimension (L×W×H)	m	9.4 x 3.4 x 2.5			9.5 x 3.6 x 2.7			11.2 x 3.9 x 2.9		12.4 x 4.2 x 3.4	
Cooling water consumption	L/min	180			180			180		180	

DL-G5
450~4300 ton

TB-G5
90~880 ton

TE-G5
50~400 ton

Option List
DL-G5 / TB-G5 / TE-G5

DL-G5
450~4300 ton

TB-G5
90~880 ton

TE-G5
50~400 ton

Option List
DL-G5 / TB-G5 / TE-G5

Platen Dimension

DL-G5(Ver.2)

Unit: mm

DL500G5 (A: 500 / B: 250) DL600G5 (A: 560 / B: 280)
DL700G5 (A: 650 / B: 400)

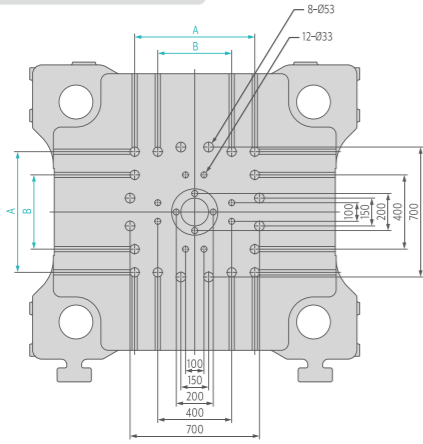

DL900G5 (A: 650 / B: 400) DL1100G5 (A: 650 / B: 440)

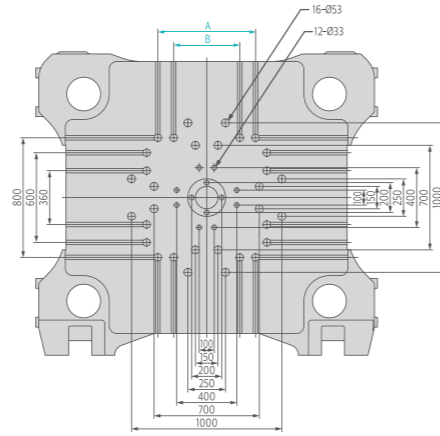

DL1350G5

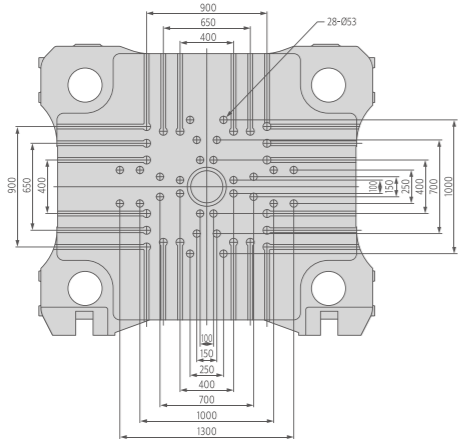

DL1850G5

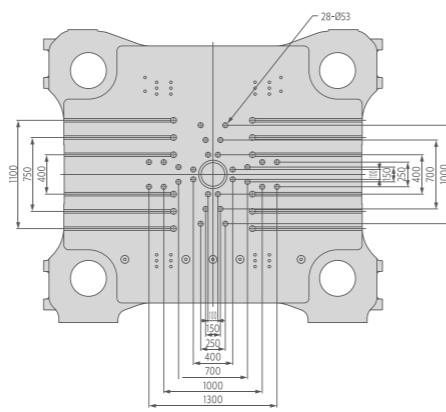

* The images and specifications might be changed without any prior notice.

Machine Dimension

DL-G5(Ver.2)

* The images and specifications might be changed without any prior notice.

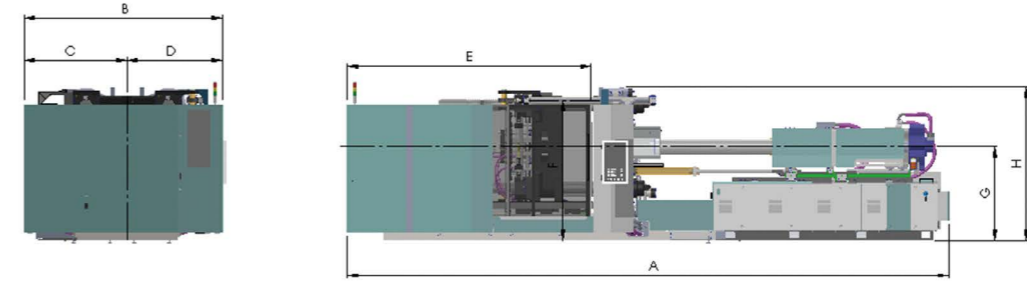

Machine Dimension

단위: mm	A	B	C	D	E	F	G	H
DL500G5	7702	2713	1452	1261	3247	1970	1410	2144
DL600G5	7907	2939	1530	1409	3341	2017	1407	2202
DL700G5	8372	3052	1564	1488	3494	2130	1450	2350
DL900G5	9515	3319	1700	1619	4016	2245	1490	2461
DL1100G5	9709	3586	1820	1766	4347	2400	1600	2665
DL1350G5	11159	3815	1935	1880	5088	2591	1725	2858
DL1850G5	12627	4123	2109	2104	5716	3035	1950	3358

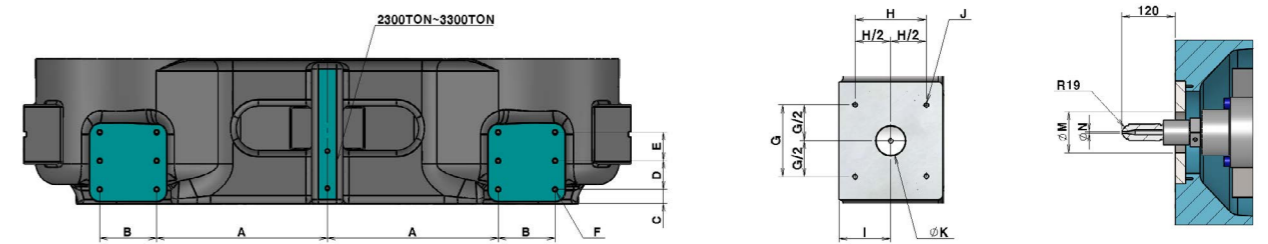

단위: mm	Robot installation position dimension						Hopper installation position dimension				Nozzle dimension		
	A	B	C	D	E	F	G	H	I	J	ØK	ØM	ØN
DL500G5	210	-	85	195	-	6-M20	165	165	120	4-M12	68	100	4
DL600G5	195	-	85	245	-	6-M20	165	165	130	4-M12	78	100	5
DL700G5	235	-	80	300	-	6-M24	165	165	140	4-M12	88	100	5
DL900G5	235	-	85	330	-	6-M24	165	165	170	4-M12	103	100	6
DL1100G5	335	-	85	375	-	6-M30	165	165	170	4-M12	103	100	6
DL1350G5	335	-	120	345	-	6-M30	280	200	190	4-M16	113	120	6
DL1850G5	495	-	115	485	-	6-M30	280	200	112	4-M16	123	120	7

TB-G5

Power-saving hydraulic IMM(90~880 ton)

TB-G5 series is power-saving hydraulic injection molding machine with Korean technology based on servo drive and controller with excellent performance as well as energy efficiency.



Mold adjustment brake motor

- Maintains constant clamping force by preventing mold slipping

Application of double center press integrated movable platen

- Evenly marvelous distributed mold pressure and achievement of mold protection

Applied seamless pipe

- Prevents corrosion and minimizes frictional resistance with excellent surface roughness
- High pressure capability, pollution prevention

Controller (IMC 710)

- WOOJIN PLAIMM (Korea)
- 15 inch Touch Screen (IPS LCD)
- Resolution : 786 x 1024
- Supports international language

Dual pull nozzle touch cylinder

- Improved nozzle touch precision
- When opening the mold, protect the mold by adjusting the system force.

Back pressure closed-loop control

- Excellent back-pressure adjustment through the closed-loop control.
- The exact amount of resin input, Injection with high precision, repeatability and high response are all achieved.

Application of LM guide to injection unit

- Enhance the parallelism and straightness on the injection unit.

Hydraulic oil independent circulation system

- Improved filtering and cooling capabilities
- Increased hydraulic oil lifespan

Servo pump system

- Prompt response time and high accuracy with optimized efficiency plus low noise.

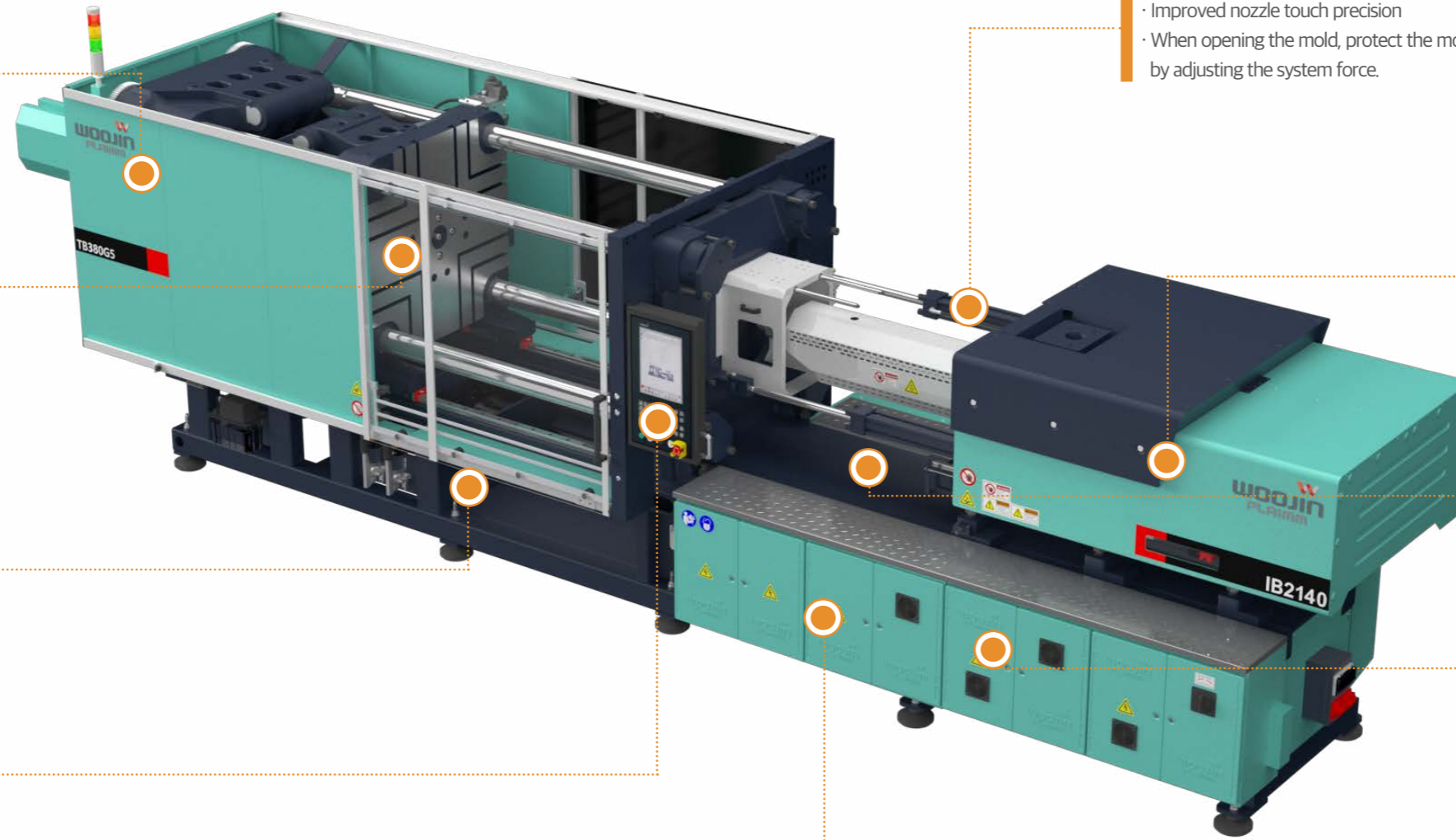

High-quality implementation with top-of-the-line performance brand components

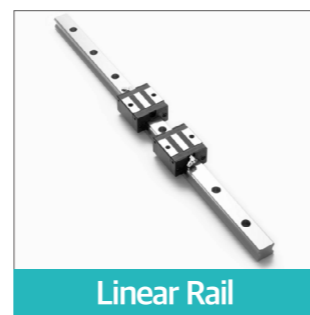
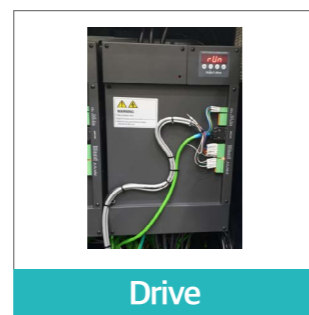

DL-G5
450~4300 ton

TB-G5
90~880 ton

TE-G5
50~400 ton

Option List
DL-G5 / TB-G5 / TE-G5

DL-G5
450~4300 ton

TB-G5
90~880 ton

TE-G5
50~400 ton

Option List
DL-G5 / TB-G5 / TE-G5

Clamping Unit

01. Integral center press clamping structure

- Apply integral center press clamping structure which is designed to transfer the clamping force uniformly to the platen.
- By transferring pressure into the mold steadily, prevent damaging platen and extend the mold life.
- Maintaining the inner surface pressure equally to prevent the flash.

03. X shape platen design

- Optimized X shape platen design ensures rigidity of platen and reduces inertia to manage machine load and increase energy saving effect.

02. Apply L/M guide on moving platen

- Improve parallelism between fixed platen and moving platen by processing the surface of L/M guide.
- Using less grease than roller type so as to sustain cleanliness.
- Apply heavy weight L/M guide to improve the precision during clamping unit operation.
- Enhanced durability to extend the component's lifespan and energy saving by friction reduction.

04. Mold adjustment brake motor

- Keep user-set clamping forces and position values constant despite repetitive clamping movement.
- Prevents clamping location moving from mold opening and closing movement.

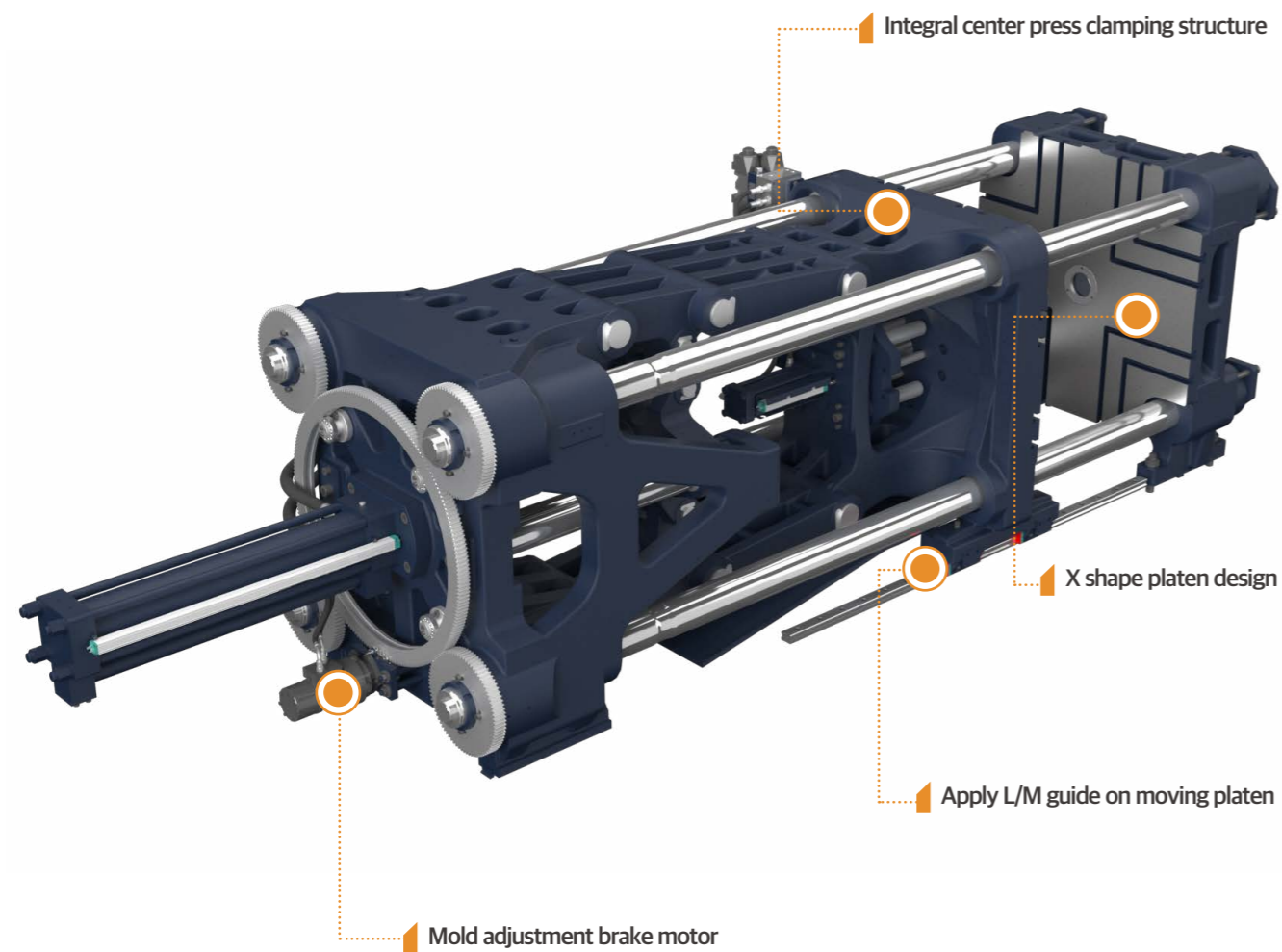

Injection Unit

01. Dual pull nozzle touch cylinder

- Improving molding precision by stabilized nozzle touch.

02. Injection back pressure controlled by closed-loop system

- Minimize the difference between the user's setting value and actual figures. (Improving back pressure controlling capability)

03. Dual cylinder for injection unit

- Symmetry injection cylinders on left and right for improved stability and responsiveness as well as enhanced balance.
- Minimize the mechanical shock and defect in molding process during the injection motion.

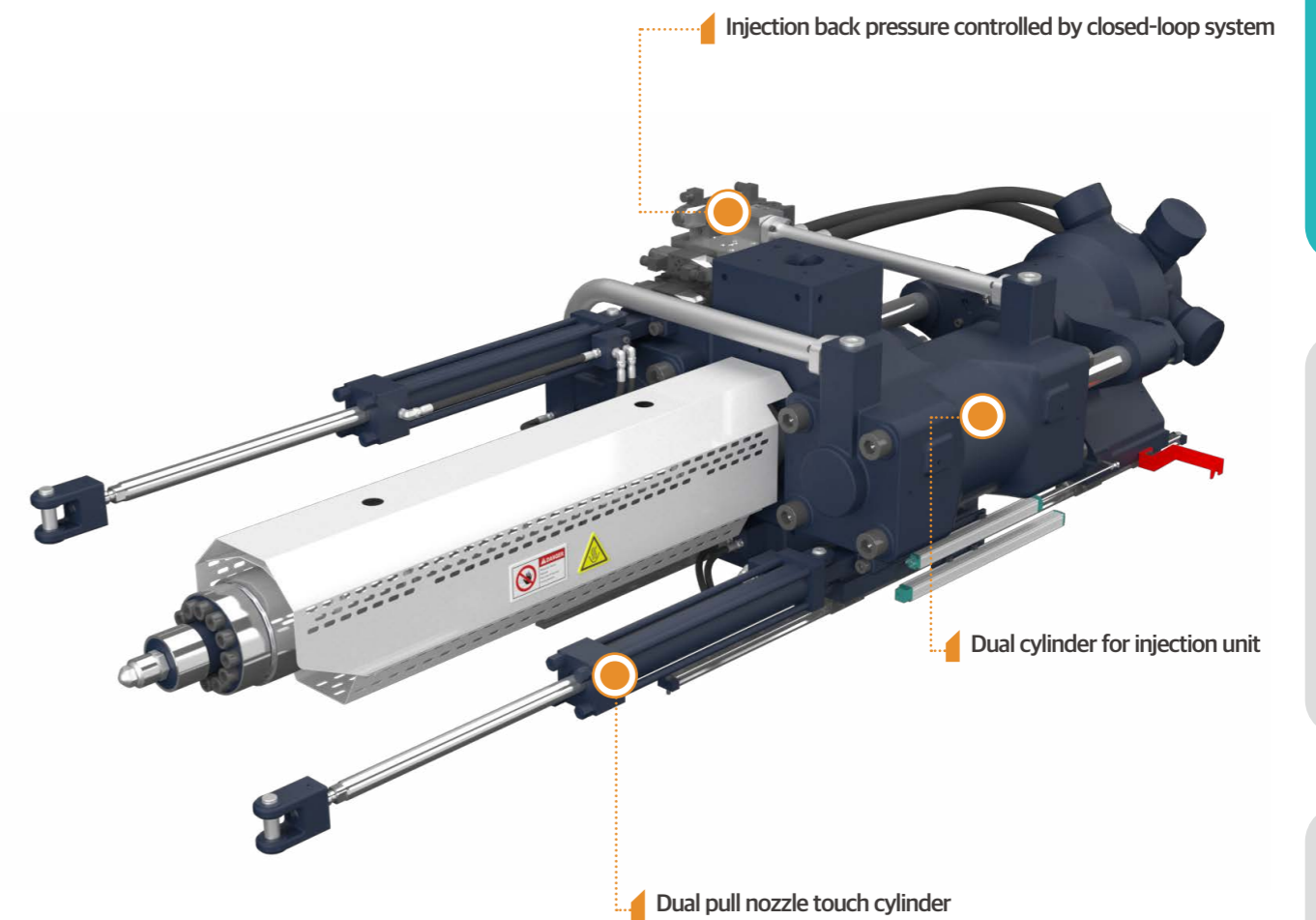

Hydraulic Unit

01. Oil tank circulation type

- Independent circulation system for oil cooling and filtering.
- Enhancing the hydraulic component's durability, oil leakage prevention and oil's lifespan extension.

02. Servo pump system

- Reduce unnecessary energy consumption by controlling servo motor rotation.
- Improved injection molding precision by accurate speed & pressure control through servo motor system.
- Reduction of cooling water consumption for hydraulic oil.

03. Applied high pressure hydraulic system

- High pressure hydraulic system has been applied to 175 bar from 140 bar.
- Reduced oil tank size due to less consumption of oil based on high pressure system.

04. Applied seamless pipe

- Coated seamless pipe and fitting applied.

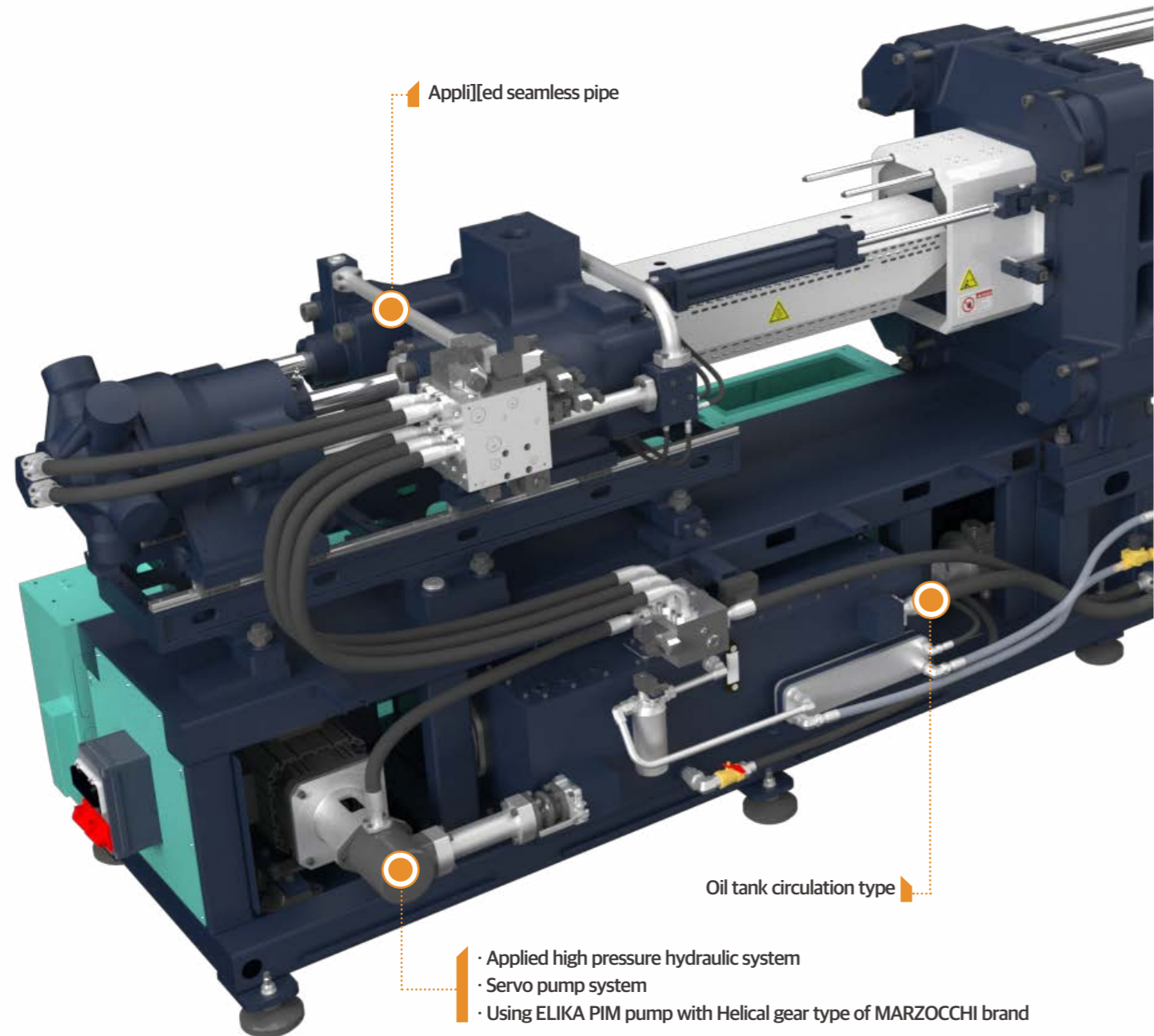

- Applied high pressure hydraulic system
- Servo pump system
- Using ELIKA PIM pump with Helical gear type of MARZOCCHI brand

Specification TB-G5

Model	TB90G5						
	IB260			IB280			
Injection Unit							
Screw & Barrel type		O	A	B	O	A	B
Screw diameter	mm	25	28	30	28	30	35
Injection pressure	kg/cm ²	2974	2952	2571	2952	2571	1889
	Mpa	292	289	252	289	252	185
Theoretical injection volume	cm ³	69	86	99	92	106	144
Shot weight (PS)	g	63	79	91	85	98	133
Injection rate	cm ³ /s	50	63	72	63	72	98
Screw stroke	mm	140			150		
Injection speed	mm/s	102			102		
Plasticizing capacity (PS)	kg/h	22	29	34	28	32	57
	rpm	280			270		
Clamping Unit							
Clamping force	ton(kN)	90 (882)					
Distance between tie-bar (H×V)	mm	360 x 360					
Platen dimension (H×V)	mm	570 x 570					
Stroke	mm	330					
Max. Daylight	mm	680					
Min. mold height	mm	140					
Max. mold height	mm	350					
Ejector force	ton(kN)	3.4 (33)					
Ejector stroke	mm	80					
General							
Heater capacity	kW	6.3	6.9	6.9	6.9		
Motor capacity	kW	12			12		
Total electric power capacity	kW	18.4	19.0	18.9	18.9		
Hydraulic oil tank capacity	L	190			190		
Machine weight (Clamping+Injection)	ton	3.6			3.6		
Machine dimension (L×W×H)	m	4.7 x 1.3 x 1.9			4.7 x 1.3 x 1.9		
Cooling water consumption	L/min	30			30		

DL-G5
450~4300 ton

TB-G5
90~880 ton

TE-G5
50~400 ton

Option List
DL-G5 / TB-G5 / TE-G5

DL-G5
450~4300 ton

TB-G5
90~880 ton

TE-G5
50~400 ton

Option List
DL-G5 / TB-G5 / TE-G5

Specification **TB-G5**

Model		TB120G5								
		IB260			IB280			IB580		
Injection Unit										
Screw & Barrel type		O	A	B	O	A	B	O	A	B
Screw diameter	mm	25	28	30	28	30	35	35	40	45
Injection pressure	kg/cm ²	2974	2952	2571	2952	2571	1889	3064	2346	1854
	Mpa	292	289	252	289	252	185	301	230	182
Theoretical injection volume	cm ³	69	86	99	92	106	144	192	251	318
Shot weight (PS)	g	63	79	91	85	98	133	177	232	293
Injection rate	cm ³ /s	50	63	72	63	72	98	104	136	172
Screw stroke	mm	140			150			200		
Injection speed	mm/s	102			102			108		
Plasticizing capacity (PS)	kg/h	22	29	34	28	32	57	53	75	98
Screw rotation speed	rpm	280			270			255		
Clamping Unit										
Clamping force	ton(kN)	120 (1176)								
Distance between tie-bar (H×V)	mm	410 x 410								
Platen dimension (H×V)	mm	630 x 630								
Stroke	mm	370								
Max. Daylight	mm	770								
Min. mold height	mm	150								
Max. mold height	mm	400								
Ejector force	ton(kN)	3.4 (33)								
Ejector stroke	mm	100								
General										
Heater capacity	kW	6.9			6.9			10		
Motor capacity	kW	12			12			20.4		
Total electric power capacity	kW	18.9			18.9			30.4		
Hydraulic oil tank capacity	L	190			190			190		
Machine weight (Clamping+Injection)	ton	4.1			4.1			4.5		
Machine dimension (L×W×H)	m	4.9 x 1.4 x 1.9			4.9 x 1.4 x 1.9			5.1 x 1.4 x 1.9		
Cooling water consumption	L/min	30			30			30		

01. Theoretical injection volume: cross section of screw*screw stroke.
02. The minimum mold size should be more than 70% of tie-bar distance.

03. The specifications might be changed without any prior notice.
04. The metering distance is recommended in the range of 1 to 3 times of screw diameter.

Model		TB160G5								
		IB280			IB580			IB640		
Injection Unit										
Screw & Barrel type		O	A	B	O	A	B	O	A	B
Screw diameter	mm	28	30	35	35	40	45	40	45	50
Injection pressure	kg/cm ²	2952	2571	1889	3064	2346	1854	2346	1854	1502
	Mpa	289	252	185	301	230	182	230	182	147
Theoretical injection volume	cm ³	92	106	144	192	251	318	276	350	432
Shot weight (PS)	g	85	98	133	177	232	293	255	322	398
Injection rate	cm ³ /s	110	126	172	104	136	172	136	172	213
Screw stroke	mm	150			200			220		
Injection speed	mm/s	179			108			108		
Plasticizing capacity (PS)	kg/h	28	32	57	53	75	98	75	98	137
Screw rotation speed	rpm	270			255			255		
Clamping Unit										
Clamping force	ton(kN)	160 (1568)								
Distance between tie-bar (H×V)	mm	460 x 460								
Platen dimension (H×V)	mm	690 x 690								
Stroke	mm	405								
Max. Daylight	mm	855								
Min. mold height	mm	180								
Max. mold height	mm	450								
Ejector force	ton(kN)	4.2 (41)								
Ejector stroke	mm	120								
General										
Heater capacity	kW	6.9			10			12.1		
Motor capacity	kW	20.4			20.4			20.4		
Total electric power capacity	kW	27.3			30.4			32.5		
Hydraulic oil tank capacity	L	260			260			260		
Machine weight (Clamping+Injection)	ton	4.8			5.2			5.2		
Machine dimension (L×W×H)	m	5.2 x 1.5 x 1.9			5.2 x 1.5 x 1.9			5.2 x 1.5 x 1.9		
Cooling water consumption	L/min	30			30			30		

DL-G5
450~4300 ton

TB-G5
90~880 ton

TE-G5
50~400 ton

Option List
DL-G5 / TB-G5 / TE-G5

DL-G5
450~4300 ton

TB-G5
90~880 ton

TE-G5
50~400 ton

Option List
DL-G5 / TB-G5 / TE-G5

Specification TB-G5

Model	TB200G5									
	IB580			IB640			IB1040			
Injection Unit										
Screw & Barrel type		O	A	B	O	A	B	O	A	B
Screw diameter	mm	35	40	45	40	45	50	45	50	55
Injection pressure	kg/cm ²	3064	2346	1854	2346	1854	1502	2765	2240	1851
	Mpa	301	230	182	230	182	147	271	220	182
Theoretical injection volume	cm ³	192	251	318	276	350	432	398	491	594
Shot weight (PS)	g	177	232	293	255	322	398	366	452	547
Injection rate	cm ³ /s	104	136	172	136	172	213	152	188	227
Screw stroke	mm	200			220			250		
Injection speed	mm/s	108			108			96		
Plasticizing capacity (PS)	kg/h	53	75	98	75	98	137	85	119	143
Screw rotation speed	rpm	255			255			220		
Clamping Unit										
Clamping force	ton(kN)	200 (1960)								
Distance between tie-bar (H×V)	mm	510 x 510								
Platen dimension (H×V)	mm	760 x 760								
Stroke	mm	460								
Max. Daylight	mm	960								
Min. mold height	mm	180								
Max. mold height	mm	500								
Ejector force	ton(kN)	4.2 (41)								
Ejector stroke	mm	140								
General										
Heater capacity	kW	10			12.1			14.4		
Motor capacity	kW	20.4			20.4			28.3		
Total electric power capacity	kW	30.4			32.5			42.7		
Hydraulic oil tank capacity	L	260			260			260		
Machine weight (Clamping+Injection)	ton	5.9			5.9			6.2		
Machine dimension (L×W×H)	m	5.4 x 1.5 x 2.0			5.4 x 1.5 x 2.0			5.7 x 1.5 x 2.0		
Cooling water consumption	L/min	30			30			30		

01. Theoretical injection volume: cross section of screw*screw stroke.
02. The minimum mold size should be more than 70% of tie-bar distance.

03. The specifications might be changed without any prior notice.
04. The metering distance is recommended in the range of 1 to 3 times of screw diameter.

Model	TB240G5									
	IB640			IB1040			IB1320			
Injection Unit										
Screw & Barrel type		O	A	B	O	A	B	O	A	B
Screw diameter	mm	40	45	50	45	50	55	50	55	60
Injection pressure	kg/cm ²	2346	1854	1502	2765	2240	1851	2559	2114	1777
	Mpa	230	182	147	271	220	182	251	207	174
Theoretical injection volume	cm ³	276	350	432	398	491	594	550	665	792
Shot weight (PS)	g	255	322	398	366	452	547	507	613	730
Injection rate	cm ³ /s	180	227	280	152	188	227	193	234	278
Screw stroke	mm	220			250			280		
Injection speed	mm/s	143			96			98		
Plasticizing capacity (PS)	kg/h	75	98	137	85	119	143	108	130	160
Screw rotation speed	rpm	255			220			200		
Clamping Unit										
Clamping force	ton(kN)	240 (2352)								
Distance between tie-bar (H×V)	mm	560 x 560								
Platen dimension (H×V)	mm	840 x 840								
Stroke	mm	520								
Max. Daylight	mm	1120								
Min. mold height	mm	200								
Max. mold height	mm	600								
Ejector force	ton(kN)	5.8 (57)								
Ejector stroke	mm	150								
General										
Heater capacity	kW	12.1			14.4			16.8		
Motor capacity	kW	28.3			28.3			36.7		
Total electric power capacity	kW	40.4			42.7			53.5		
Hydraulic oil tank capacity	L	320			320			320		
Machine weight (Clamping+Injection)	ton	7.7			7.9			8.1		
Machine dimension (L×W×H)	m	6.3 x 1.6 x 1.9			6.3 x 1.6 x 1.9			6.5 x 1.6 x 1.9		
Cooling water consumption	L/min	30			30			30		

DL-G5
450~4300 ton

TB-G5
90~880 ton

TE-G5
50~400 ton

Option List
DL-G5 / TB-G5 / TE-G5

DL-G5
450~4300 ton

TB-G5
90~880 ton

TE-G5
50~400 ton

Option List
DL-G5 / TB-G5 / TE-G5

Specification TB-G5

Model	TB280G5									
	IB1040			IB1320			IB2140			
Injection Unit										
Screw & Barrel type		O	A	B	O	A	B	O	A	B
Screw diameter	mm	45	50	55	50	55	60	65	70	75
Injection pressure	kg/cm ²	2765	2240	1851	2559	2114	1777	2071	1786	1556
	Mpa	271	220	182	251	207	174	203	175	153
Theoretical injection volume	cm ³	398	491	594	550	665	792	1062	1232	1414
Shot weight (PS)	g	366	452	547	507	613	730	979	1135	1303
Injection rate	cm ³ /s	179	221	267	193	234	278	302	350	402
Screw stroke	mm	250			280			320		
Injection speed	mm/s	112			98			91		
Plasticizing capacity (PS)	kg/h	85	119	143	108	130	160	151	193	232
Screw rotation speed	rpm	220			200			148		
Clamping Unit										
Clamping force	ton(kN)	280 (2744)								
Distance between tie-bar (H×V)	mm	610 x 610								
Platen dimension (H×V)	mm	920 x 920								
Stroke	mm	570								
Max. Daylight	mm	1220								
Min. mold height	mm	250								
Max. mold height	mm	650								
Ejector force	ton(kN)	5.8 (57)								
Ejector stroke	mm	170								
General										
Heater capacity	kW	14.4			16.8			26.4		
Motor capacity	kW	36.7			36.7			43		
Total electric power capacity	kW	51.1			53.5			69.4		
Hydraulic oil tank capacity	L	400			400			400		
Machine weight (Clamping+Injection)	ton	9.7			10.1			10.5		
Machine dimension (L×W×H)	m	6.8 x 1.7 x 1.9			6.8 x 1.7 x 1.9			7.1 x 1.7 x 1.9		
Cooling water consumption	L/min	30			30			30		

01. Theoretical injection volume: cross section of screw*screw stroke.
02. The minimum mold size should be more than 70% of tie-bar distance.

03. The specifications might be changed without any prior notice.
04. The metering distance is recommended in the range of 1 to 3 times of screw diameter.

Model	TB380G5										
	IB1320			IB2140			IB2610				
Injection Unit											
Screw & Barrel type		O	A	B	O	A	B	O	A	B	
Screw diameter	mm	50	55	60	65	70	75	65	70	80	
Injection pressure	kg/cm ²	2559	2114	1777	2071	1786	1556	2071	1786	1367	
	Mpa	251	207	174	203	175	153	203	175	134	
Theoretical injection volume	cm ³	550	665	792	1062	1232	1414	1294	1501	1960	
Shot weight (PS)	g	507	613	730	979	1135	1303	1193	1383	1806	
Injection rate	cm ³ /s	245	296	352	302	350	402	302	350	458	
Screw stroke	mm	280			320			390			
Injection speed	mm/s	125			91			91			
Plasticizing capacity (PS)	kg/h	108	130	160	151	193	232	136	166	235	
Screw rotation speed	rpm	200			148			141			
Clamping Unit											
Clamping force	ton(kN)	380 (3724)									
Distance between tie-bar (H×V)	mm	710 x 710									
Platen dimension (H×V)	mm	1065 x 1065									
Stroke	mm	700									
Max. Daylight	mm	1450									
Min. mold height	mm	300									
Max. mold height	mm	750									
Ejector force	ton(kN)	8.8 (86)									
Ejector stroke	mm	200									
General											
Heater capacity	kW	16.8			26.4			18.4	20.6	24.1	
Motor capacity	kW	43			43			43			
Total electric power capacity	kW	59.8			69.4			61.4	63.6	67.1	
Hydraulic oil tank capacity	L	500			500			500			
Machine weight (Clamping+Injection)	ton	14.2			14.7			15.2			
Machine dimension (L×W×H)	m	8.0 x 1.9 x 2.1			8.0 x 1.9 x 2.1			8.5 x 1.9 x 2.1			
Cooling water consumption	L/min	60			60			60			

DL-G5
450~4300 ton

TB-G5
90~880 ton

TE-G5
50~400 ton

Option List
DL-G5 / TB-G5 / TE-G5

DL-G5
450~4300 ton

TB-G5
90~880 ton

TE-G5
50~400 ton

Option List
DL-G5 / TB-G5 / TE-G5

Specification **TB-G5**

Model	TB480G5									
	IB2140			IB2610			IB4200			
Injection Unit										
Screw & Barrel type		O	A	B	O	A	B	O	A	B
Screw diameter	mm	65	70	75	65	70	80	70	80	90
Injection pressure	kg/cm ²	2071	1786	1556	2071	1786	1367	2465	1887	1491
	Mpa	203	175	153	203	175	134	242	185	146
Theoretical injection volume	cm ³	1062	1232	1414	1294	1501	1960	1693	2212	2799
Shot weight (PS)	g	979	1135	1303	1193	1383	1806	1560	2038	2579
Injection rate	cm ³ /s	302	350	402	302	350	458	401	524	663
Screw stroke	mm	320			390			440		
Injection speed	mm/s	91			91			104		
Plasticizing capacity (PS)	kg/h	151	193	232	136	166	235	212	266	319
Screw rotation speed	rpm	148			141			180	160	141
Clamping Unit										
Clamping force	ton(kN)	480 (4704)								
Distance between tie-bar (H×V)	mm	830 x 830								
Platen dimension (H×V)	mm	1220 x 1220								
Stroke	mm	780								
Max. Daylight	mm	1580								
Min. mold height	mm	350								
Max. mold height	mm	800								
Ejector force	ton(kN)	13.7 (134)								
Ejector stroke	mm	200								
General										
Heater capacity	kW	26.4	18.4	20.6	24.1	23	26.7	30.7		
Motor capacity	kW	43	43			71.3				
Total electric power capacity	kW	69.4	61.4	63.6	67.1	94.3	98.0	102.0		
Hydraulic oil tank capacity	L	500	500			800				
Machine weight (Clamping+Injection)	ton	20.4	20.4			26				
Machine dimension (L×W×H)	m	8.8 x 2.0 x 2.2			8.8 x 2.0 x 2.2			9.2 x 2.3 x 2.2		
Cooling water consumption	L/min	60	60			60				

01. Theoretical injection volume: cross section of screw*screw stroke.
 02. The minimum mold size should be more than 70% of tie-bar distance.

03. The specifications might be changed without any prior notice.
 04. The metering distance is recommended in the range of 1 to 3 times of screw diameter.

Model	TB580G5						
	IB4200			IB5900			
Injection Unit							
Screw & Barrel type		O	A	B	O	A	B
Screw diameter	mm	70	80	90	80	90	105
Injection pressure	kg/cm ²	2465	1887	1491	2386	1885	1385
	Mpa	242	185	146	234	185	136
Theoretical injection volume	cm ³	1693	2212	2799	2488	3149	4286
Shot weight (PS)	g	1560	2038	2579	2293	2902	3950
Injection rate	cm ³ /s	401	524	663	502	636	866
Screw stroke	mm	440			495		
Injection speed	mm/s	104			100		
Plasticizing capacity (PS)	kg/h	212	266	319	241	319	433
Screw rotation speed	rpm	180	160	141	145	141	129
Clamping Unit							
Clamping force	ton(kN)	580 (5684)					
Distance between tie-bar (H×V)	mm	980 x 980					
Platen dimension (H×V)	mm	1435 x 1365					
Stroke	mm	900					
Max. Daylight	mm	1850					
Min. mold height	mm	400					
Max. mold height	mm	950					
Ejector force	ton(kN)	16.6 (163)					
Ejector stroke	mm	240					
General							
Heater capacity	kW	23.0	26.7	30.7	29.4	33.6	39.3
Motor capacity	kW	71.3			86		
Total electric power capacity	kW	94.3	98.0	102.0	115.4	119.6	125.3
Hydraulic oil tank capacity	L	800			950		
Machine weight (Clamping+Injection)	ton	29.6			35		
Machine dimension (L×W×H)	m	9.5 x 2.3 x 2.2			10.4 x 2.3 x 2.2		
Cooling water consumption	L/min	60			60		

DL-G5
450~4300 ton

TB-G5
90~880 ton

TE-G5
50~400 ton

Option List
DL-G5 / TB-G5 / TE-G5

DL-G5
450~4300 ton

TB-G5
90~880 ton

TE-G5
50~400 ton

Option List
DL-G5 / TB-G5 / TE-G5

Specification TB-G5

Model	TB680G5									
	IB4200			IB5900			IB8900			
Injection Unit										
Screw & Barrel type		O	A	B	O	A	B	O	A	B
Screw diameter	mm	70	80	90	80	90	105	95	105	115
Injection pressure	kg/cm ²	2465	1887	1491	2386	1885	1385	2145	1756	1464
	Mpa	242	185	146	234	185	136	210	172	144
Theoretical injection volume	cm ³	1693	2212	2799	2488	3149	4286	4147	5066	6076
Shot weight (PS)	g	1560	2038	2579	2293	2902	3950	3821	4668	5599
Injection rate	cm ³ /s	486	635	804	502	636	866	721	880	1056
Screw stroke	mm	440			495			585		
Injection speed	mm/s	126			100			102		
Plasticizing capacity (PS)	kg/h	212	266	319	241	319	433	338	416	478
Screw rotation speed	rpm	180	160	141	145	141	129	130	124	114
Clamping Unit										
Clamping force	ton(kN)	680 (6664)								
Distance between tie-bar (H×V)	mm	1080 x 1080								
Platen dimension (H×V)	mm	1550 x 1480								
Stroke	mm	1000								
Max. Daylight	mm	2100								
Min. mold height	mm	450								
Max. mold height	mm	1100								
Ejector force	ton(kN)	19.8 (194)								
Ejector stroke	mm	260								
General										
Heater capacity	kW	23.0	26.7	30.7	29.4	33.6	39.3	39.7	44.7	49.4
Motor capacity	kW	86			86			116.4		
Total electric power capacity	kW	109.0	112.7	116.7	115.4	119.6	125.3	156.1	161.1	165.8
Hydraulic oil tank capacity	L	800			950			1050		
Machine weight (Clamping+Injection)	ton	40			43			47		
Machine dimension (L×W×H)	m	10.5 x 2.3 x 2.3			10.9 x 2.4 x 2.4			11.4 x 2.4 x 2.4		
Cooling water consumption	L/min	60			60			60		

01. Theoretical injection volume: cross section of screw*screw stroke.
02. The minimum mold size should be more than 70% of tie-bar distance.

03. The specifications might be changed without any prior notice.
04. The metering distance is recommended in the range of 1 to 3 times of screw diameter.

Model	TB880G5							
	IB5900			IB8900				
Injection Unit								
Screw & Barrel type		O	A	B	O	A	B	
Screw diameter	mm	80	90	105	95	105	115	
Injection pressure	kg/cm ²	2386	1885	1385	2145	1756	1464	
	Mpa	234	185	136	210	172	144	
Theoretical injection volume	cm ³	2488	3149	4286	4147	5066	6076	
Shot weight (PS)	g	2293	2902	3950	3821	4668	5599	
Injection rate	cm ³ /s	648	820	1116	721	880	1056	
Screw stroke	mm	495			585			
Injection speed	mm/s	129			102			
Plasticizing capacity (PS)	kg/h	241	319	433	338	416	478	
Screw rotation speed	rpm	145	141	129	130	124	114	
Clamping Unit								
Clamping force	ton(kN)	880 (8624)						
Distance between tie-bar (H×V)	mm	1180 x 1180						
Platen dimension (H×V)	mm	1710 x 1650						
Stroke	mm	1200						
Max. Daylight	mm	2400						
Min. mold height	mm	500						
Max. mold height	mm	1200						
Ejector force	ton(kN)	30.9 (303)						
Ejector stroke	mm	280						
General								
Heater capacity	kW	29.4	33.6	39.3	39.7	44.7	49.4	
Motor capacity	kW	116.4			116.4			
Total electric power capacity	kW	145.8	150.0	155.7	156.1	161.1	165.8	
Hydraulic oil tank capacity	L	950			1050			
Machine weight (Clamping+Injection)	ton	43			51			
Machine dimension (L×W×H)	m	11.9 x 2.4 x 2.4			12.3 x 2.7 x 2.5			
Cooling water consumption	L/min	80			80			

DL-G5
450~4300 ton

TB-G5
90~880 ton

TE-G5
50~400 ton

Option List
DL-G5 / TB-G5 / TE-G5

DL-G5
450~4300 ton

TB-G5
90~880 ton

TE-G5
50~400 ton

Option List
DL-G5 / TB-G5 / TE-G5

Platen Dimension

TB-G5

Unit: mm

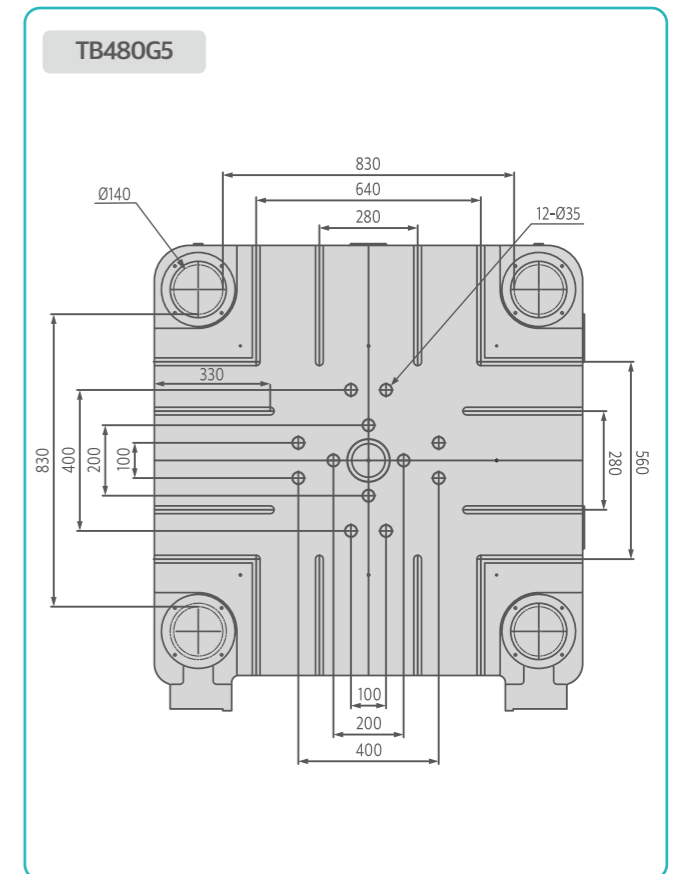
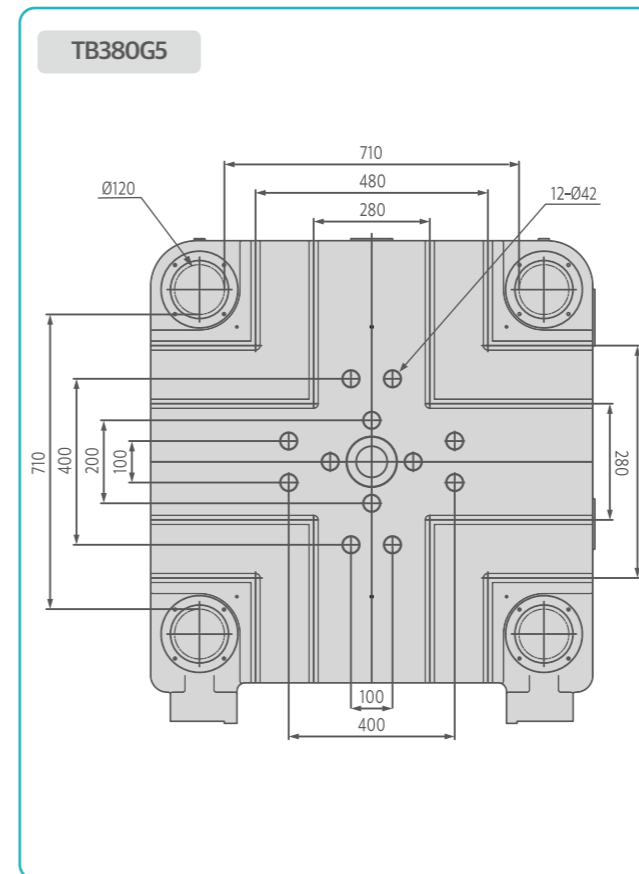
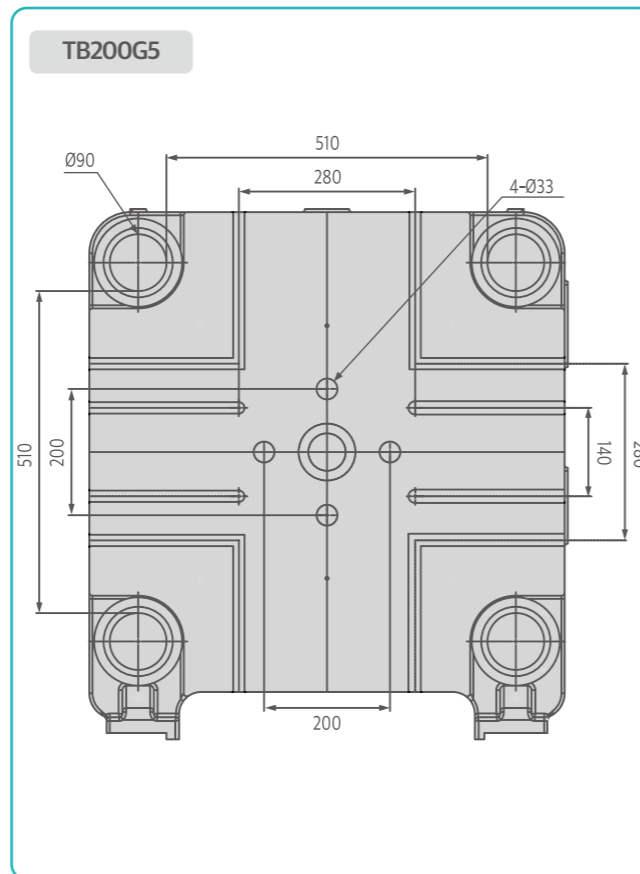
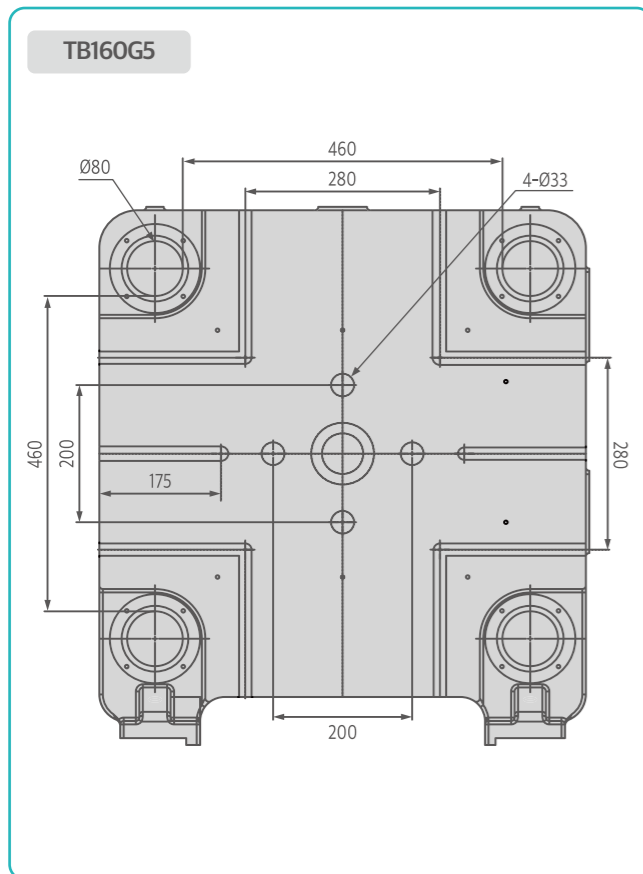
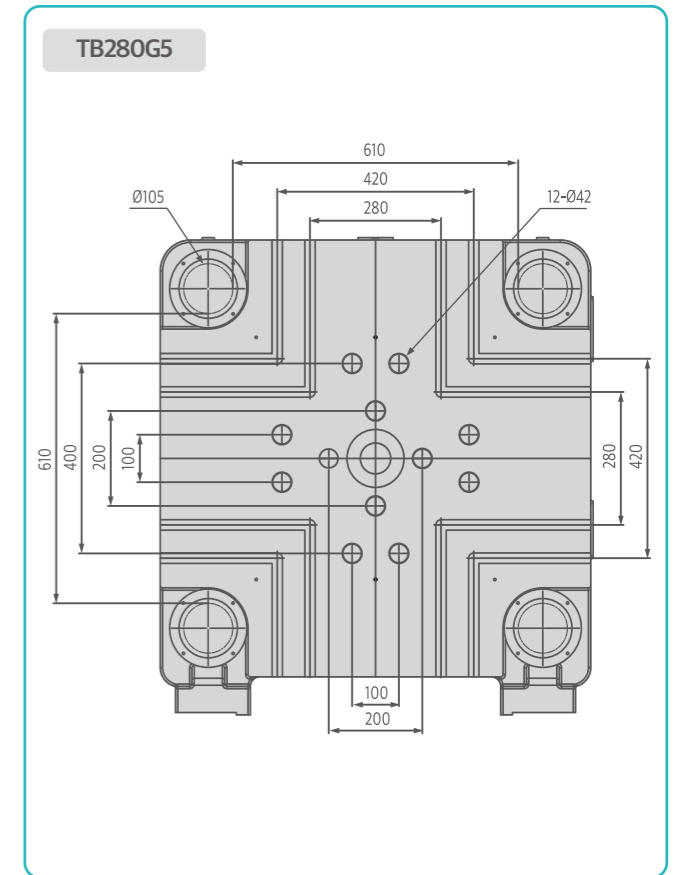
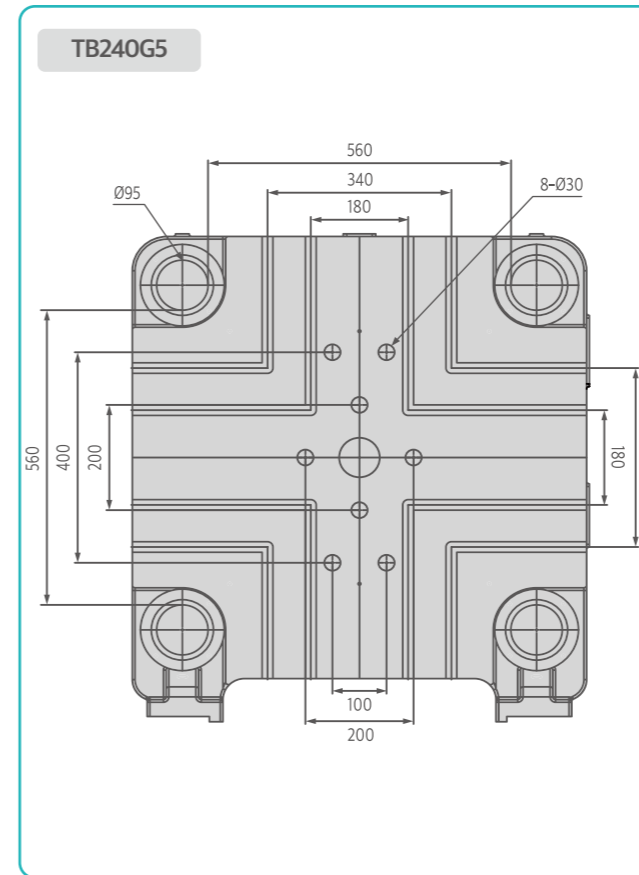
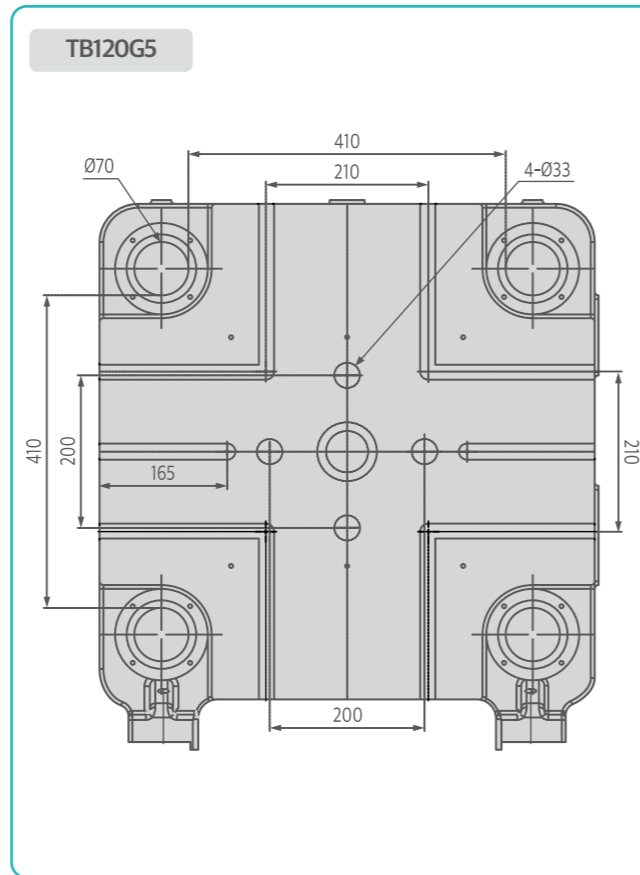
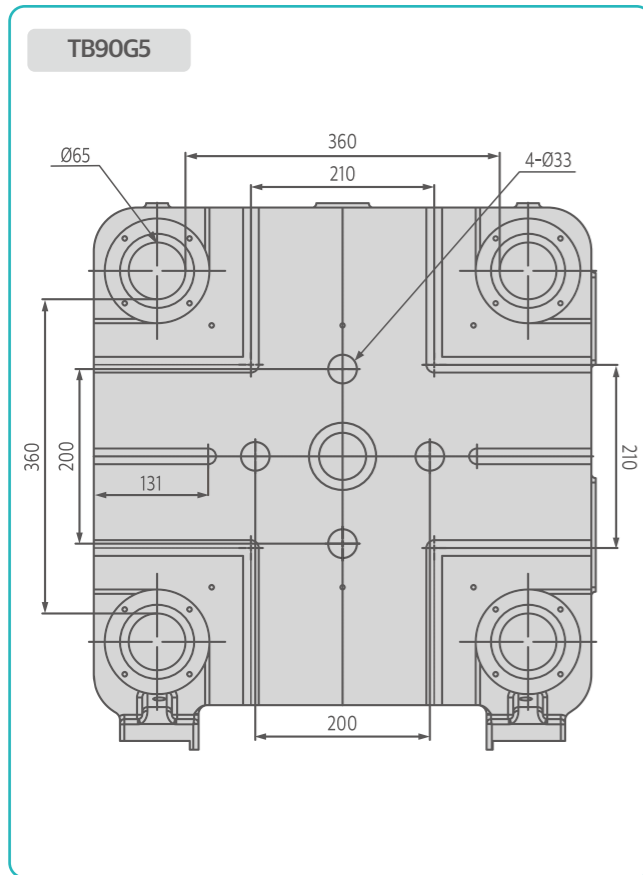

* Product images and options may change without notice due to quality improvement activities.

DL-G5
450~4300 ton

TB-G5
90~880 ton

TE-G5
50~400 ton

Option List
DL-G5 / TB-G5 / TE-G5

DL-G5
450~4300 ton

TB-G5
90~880 ton

TE-G5
50~400 ton

Option List
DL-G5 / TB-G5 / TE-G5

Platen Dimension

TB-G5

Unit: mm

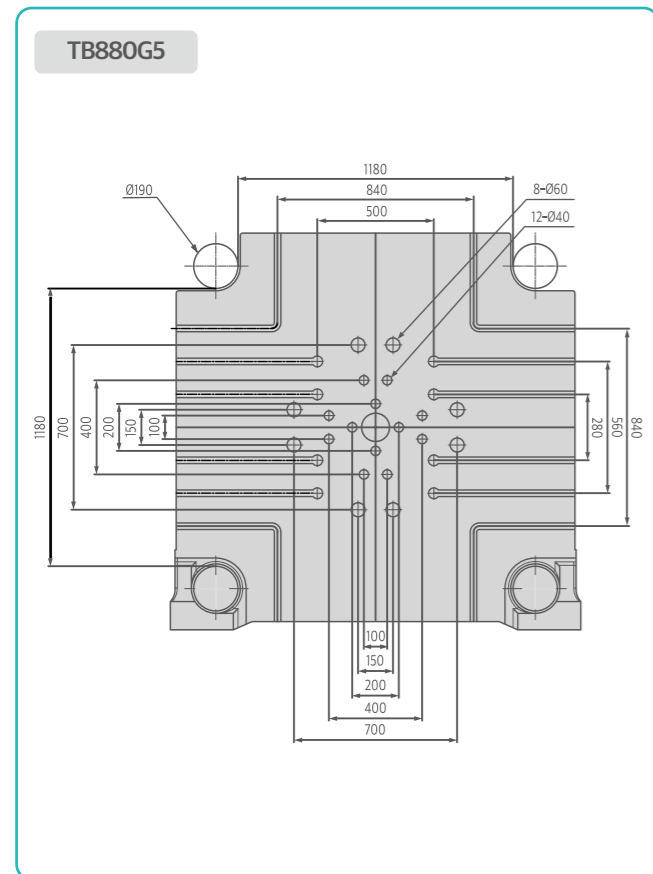
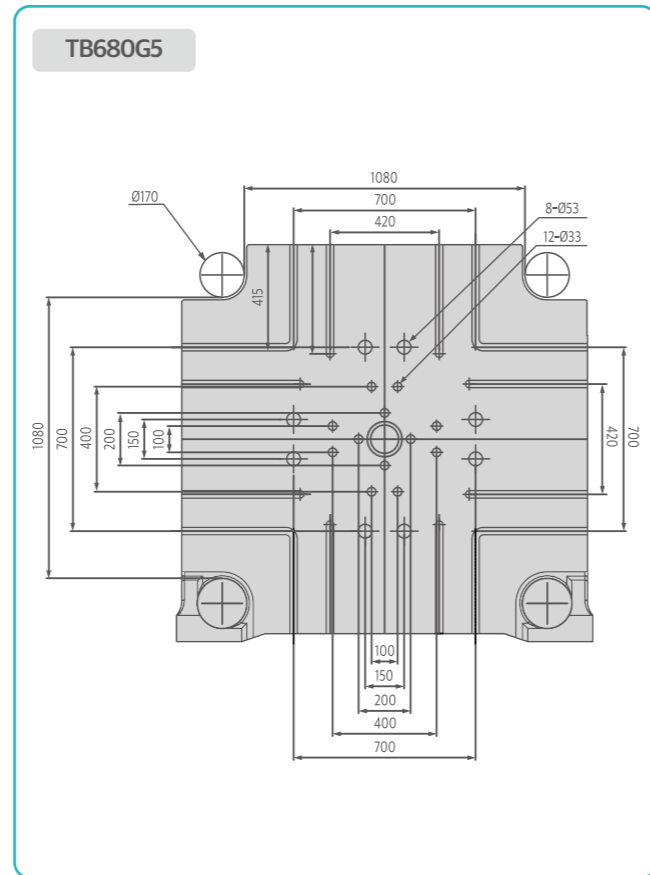
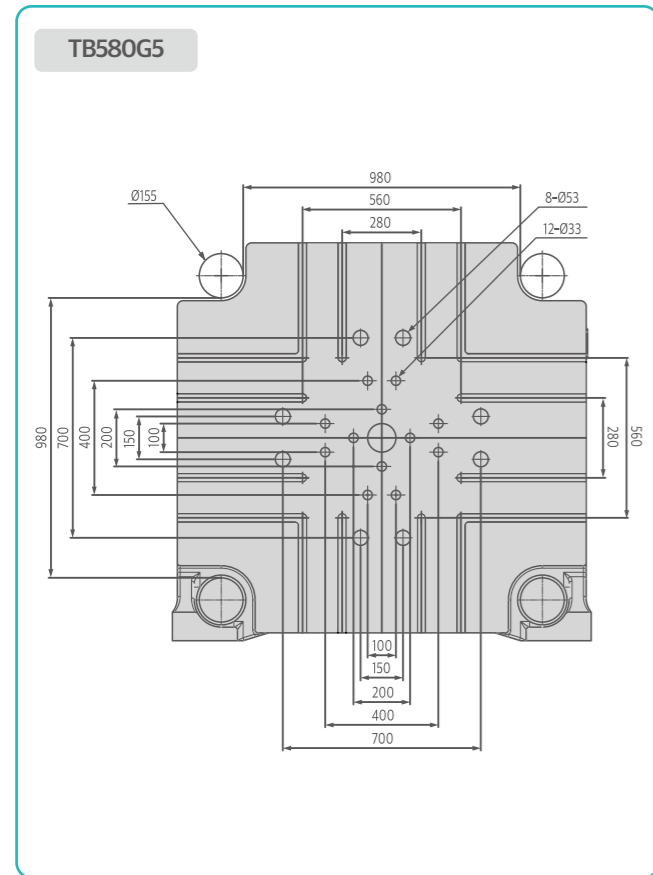

Machine Dimension

TB-G5

Unit: mm

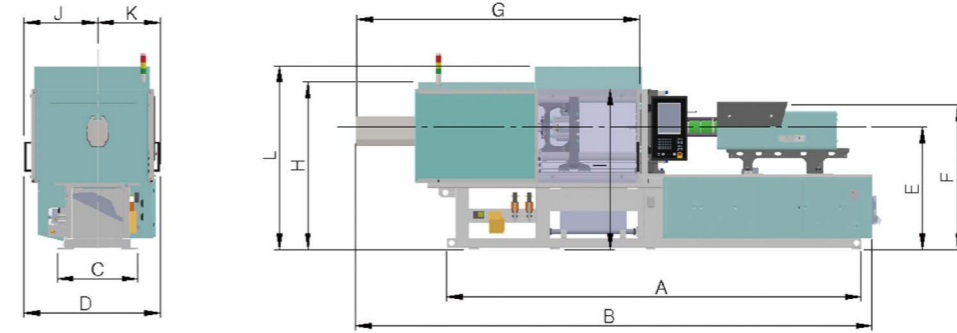

Machine Dimension												
	A	B	C	D	E	F	G	H	I	J	K	L
TB90G5	3730	4627	710	1282	1157	1397	2223	1549	1452	667	615	1836
TB120G5	3960	4873	765	1319	1212	1452	2419	1639	1542	704	615	1836
TB160G5	4275	5170	820	1405	1252	1505	2667	1709	1612	760	645	1856
TB200G5	4355	5372	850	1435	1282	1535	2851	1773	1677	775	660	1921
TB240G5	5025	6263	915	1545	1335	1640	3354	1845	1765	830	715	-
TB280G5	5505	6711	965	1667	1385	1700	3674	1900	1850	902	765	-
TB380G5	6350	7936	1110	1812	1390	1735	4316	2002	1935	982	830	-
TB480G5	6900	8721	1260	1993	1480	1815	4724	2155	2105	1083	910	-
TB580G5	7925	9811	1680	2274	1420	1590	5346	2188	2148	1250	1023	-
TB680G5	9100	10895	1715	2360	1502	1692	5879	2347	2292	1275	1085	-
TB880G5	10420	12271	1795	2672	1542	1757	6669	2532	2407	1470	1202	-

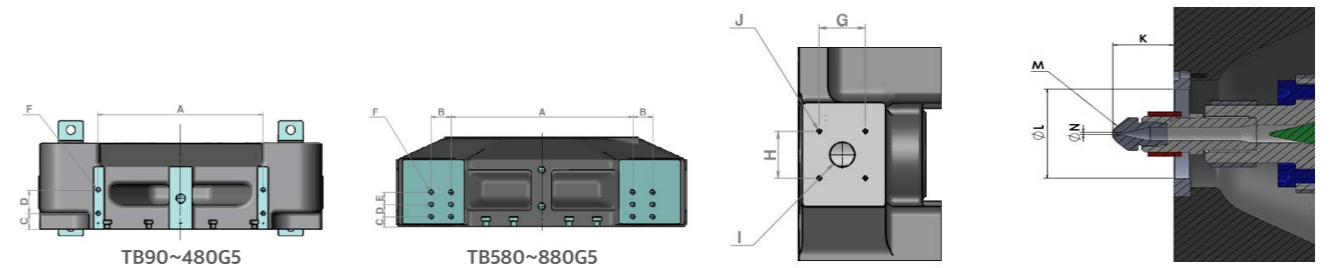

	Robot installation position dimension						Hopper installation position dimension				Nozzle dimension			
	A	B	C	D	E	F	G	H	I	J	K	ØL	M	ØN
TB90G5	280	-	57	40	-	4-M12 TAP DP24	100	100	85	4-M12 TAP	70	100	R9	2.5
TB120G5	330	-	47	40	-	4-M12 TAP DP24	100	100	85	4-M12 TAP	70	100	R9	2.5
TB160G5	380	-	40	70	-	4-M14 TAP DP28	120	120	95	4-M12 TAP	70	100	R9	2.5
TB200G5	430	-	50	70	-	4-M14 TAP DP28	120	120	95	4-M12 TAP	50	100	R9	3
TB240G5	495	-	70	70	-	4-M14 TAP DP28	120	120	100	4-M12 TAP	50	100	R9	3
TB280G5	610	-	80	70	-	4-M14 TAP DP28	120	120	100	4-M12 TAP	50	100	R9	3
TB380G5	610	-	67	100	-	4-M20 TAP DP40	127	127	90	4-M12 TAP	50	100	R14	3.5
TB480G5	720	-	67	100	-	4-M20 TAP DP40	127	127	68	4-M12 TAP	120	100	R19	4
TB580G5	915	100	50	60	60	12-M24 TAP DP48	165	165	78	4-M12 TAP	120	100	R19	5
TB680G5	1000	240	70	105	105	12-M24 TAP DP48	165	165	88	4-M12 TAP	120	100	R19	5
TB880G5	1120	240	70	105	105	12-M24 TAP DP48	165	165	103	4-M12 TAP	120	100	R19	6

* Product images and options may change without notice due to quality improvement activities.

* The images and specifications might be changed without any prior notice.

DL-G5
450~4300 ton

TB-G5
90~880 ton

TE-G5
50~400 ton

Option List
DL-G5 / TB-G5 / TE-G5

DL-G5
450~4300 ton

TB-G5
90~880 ton

TE-G5
50~400 ton

Option List
DL-G5 / TB-G5 / TE-G5

TE-G5

Power-saving electric IMM (50~400 ton)

Power-saving electric injection molding machine that ensures precision of operation by applying high profile AC servo motor and enables rapid processing with independent control for each moving part.



Clean Tie bar

- Improved tie bar cleanliness, reduced grease usage

Automatic clamp force adjustment motor

- Maintain constant clamping force

Application of double center press integrated movable platen

- Evenly marvelous distributed mold pressure and achievement of mold protection

Application of LM guide on movable plate

- Enhance the parallelism and straightness on the clamping unit.

Controller (IMC 710)

- WOOJIN PLAIMM (Korea)
- 15 inch Touch Screen (IPS LCD)
- Resolution : 786 x 1024
- Supports international language

Dual pull nozzle touch cylinder

- Symmetric dual pull nozzle touch cylinder application

Screw & Barrel

- Excellence in holding pressure & low-speed injection control.
- PID temperature control

High rigidity injection unit

- Maintain stability during high-speed injection

High-precision injection pressure detection device (load cell)

- Maintain stability during high-speed injection

Application of LM guide to injection ram box part

- Reduced moving friction, improved reproducibility

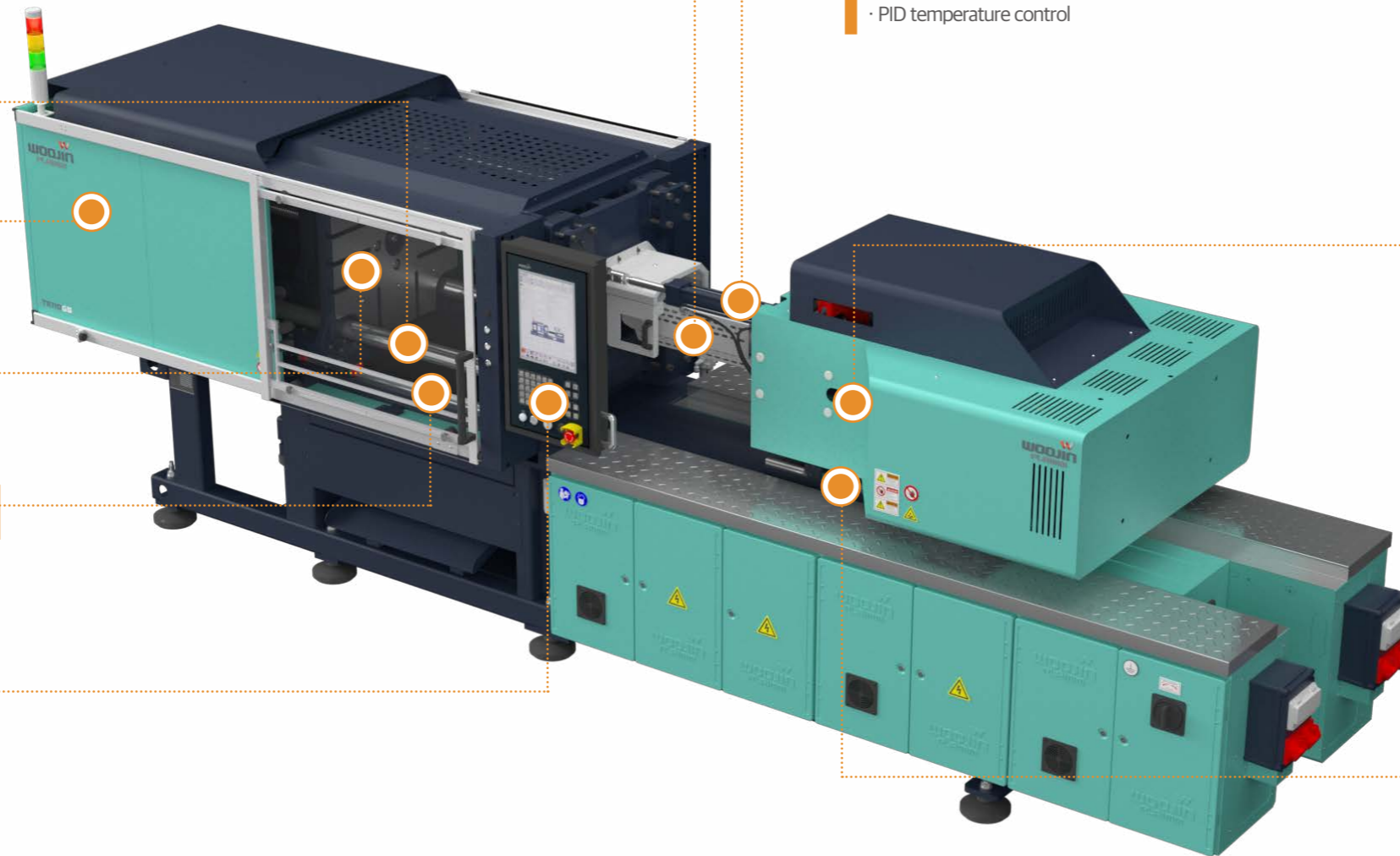

High-quality implementation with top-of-the-line performance brand components

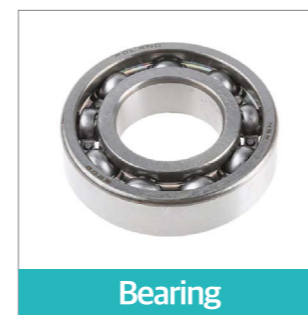
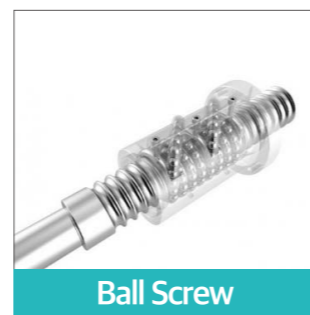
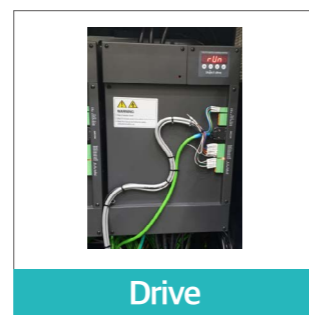

Clamping Unit

01. New Center press type platen structure

- Designed to concentrate more clamping force into the center of platen
- Improve mold precision of products and extend lifespan of the mold due to the mold's non-deformation during mold closing.

03. Improving automatic grease supply

- Improving the grease distribution method to quantitative supply method from sequential supply method.
- Consistent supply of small amount of grease to reduce consumption and prevent overfilling

05. Optimized new toggle structure

- Extending servo motor lifespan by 30% increased clamping force magnification rate and reduced load on the motor.
- *** Magnification Rate: Amplify the mold closing force**
- Enhancing acceleration and deceleration control and positioning control precision.
- Higher speed of mold opening and closing capability.

07. Wider tie-bar distance and improved maximum mold height

- Increase 10% longer than previous models.

02. L/M guide on moving platen

- Less friction resistance compared with tie bar bush method.
- Improving precise position control (0.1mm -> 0.01mm)
- Shortening mold opening and closing time due to enhanced acceleration (0.3G -> 0.5G)

04. Applied Worm gear motor

- Reduce the total length of machine of 280 ton and above by applying a worm gear motor.
- Improves design and increases rear space utilization by removing protruding cover on the rear of the clamping area.

06. Bolt clamped toggle pin type

- Stable operation even under fast mold opening and closing condition because the force to the toggle link is equal to that to the toggle pin.
- Prevent differentiation of rotating force between two articulated areas which improves of toggle during mold opening and closing.

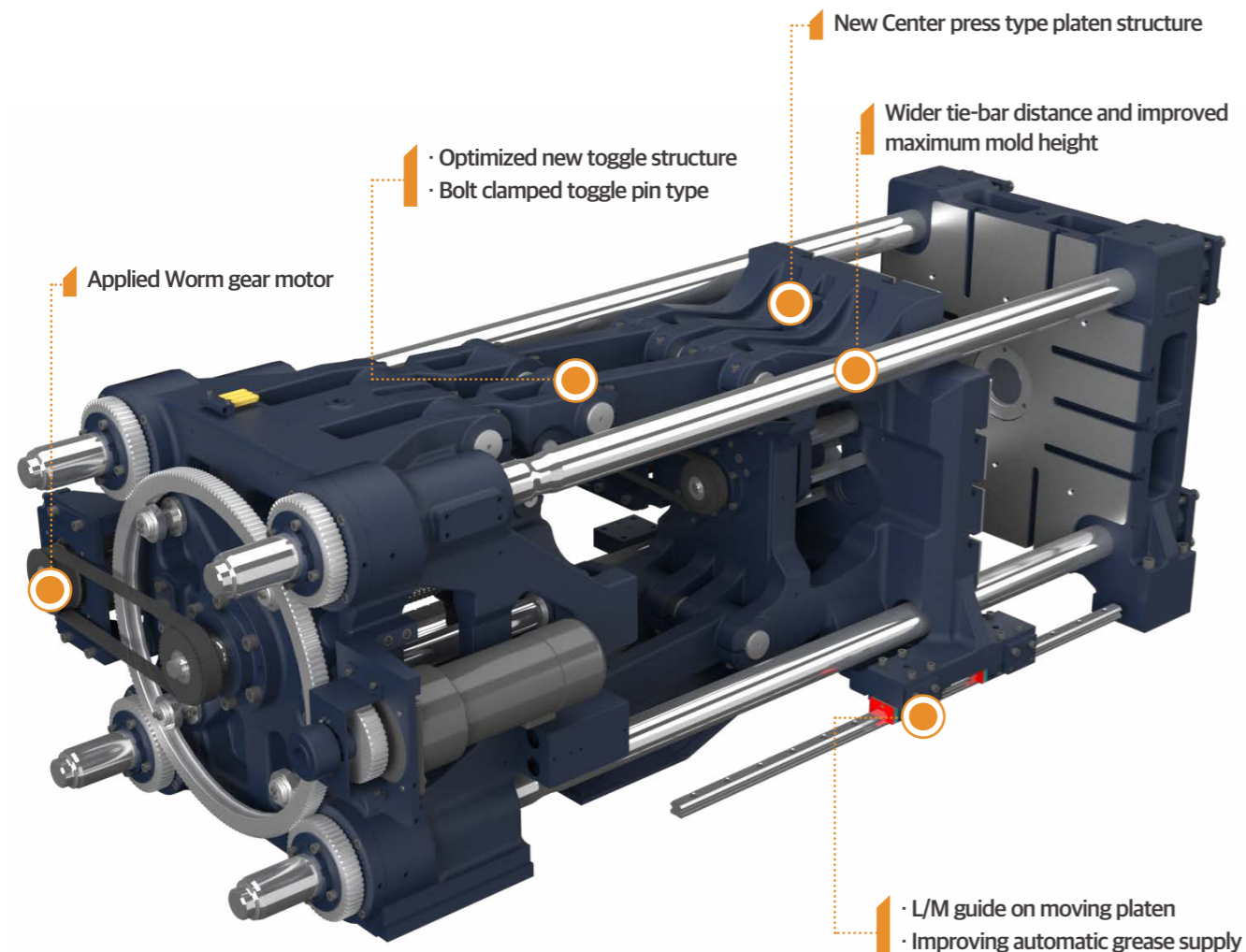

Injection Unit

01. High-rigidity in-line injection unit

- Using one casting part to accommodate injection housing and injection ball screw cabin .
- L/M guide for injection bed and charging area

02. Screw Pitch and Length

- Improved plasticization capability enables fast and uniformed resin melting and maintains cushion deviation

03. Dual pull nozzle touch cylinder

- Maintain fixed platen's perpendicular rate and injection unit's parallel rate even in repeated nozzle touch
- Prevent mold locate ring damage and improve product precision

04. High precision charging Control & Screw Reverse Rotation

- Prevent back flow of resin during injection
- Decrease charging deviation (by using reverse rotation function after charging)

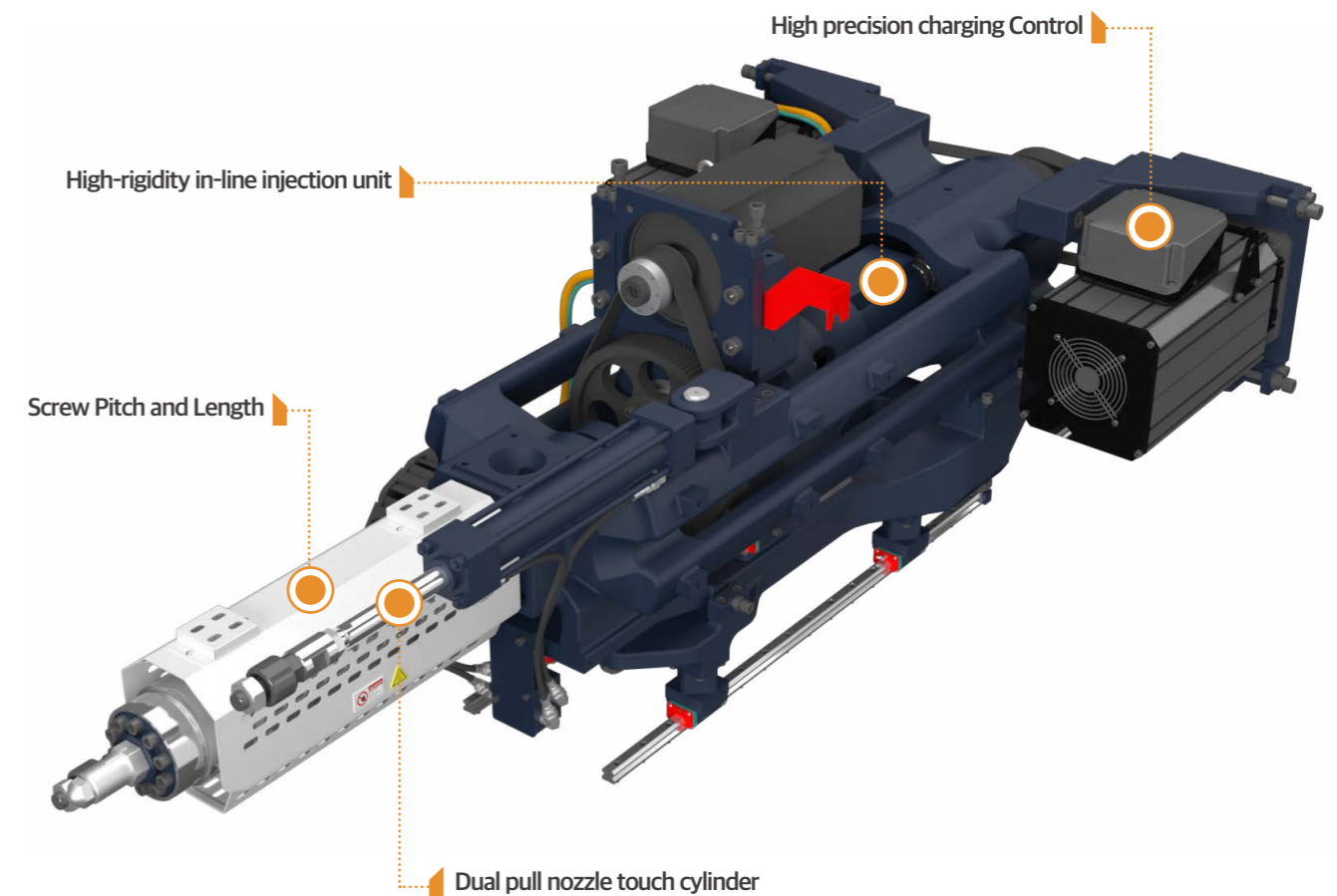

Specification **TE-G5**

Model	TE50G5						
	IE125			IE260			
Injection Unit							
Screw & Barrel type		O	A	B	O	A	B
Screw diameter	mm	22	25	28	28	32	36
Injection pressure	kg/cm ²	2609	2021	1611	2676	2049	1619
	Mpa	256	198	158	262	201	159
Injection holding pressure	kg/cm ²	2348	1819	1450	2408	1844	1457
	Mpa	230	178	142	236	181	143
Theoretical injection volume	cm ³	48	61	77	99	129	163
Shot weight (PS)	g	43	56	70	90	117	148
Injection rate	cm ³ /s	84	108	135	123	161	204
Screw stroke	mm	125			160		
Injection speed	mm/s	220			200		
Plasticizing capacity (PS)	kg/h	31	44	57	45	64	92
	rpm	500			400		
Clamping Unit							
Clamping force	ton(kN)	50(490)					
Distance between tie-bar (H×V)	mm	370 x 370					
Platen dimension (H×V)	mm	550 x 550					
Stroke	mm	300					
Max. Daylight	mm	700					
Min. mold height	mm	140					
Max. mold height	mm	400					
Ejector force	ton(kN)	1.9(19)					
Ejector stroke	mm	80					
General							
Motor capacity	kW	15			20.0		
Heater capacity	kW	4.5	5.1	5.9	7.0	7.8	9.1
Total electric power capacity	kW	19.5	20.1	20.9	27.0	27.8	29.1
Machine weight (Clamping+Injection)	ton	3.9			4.2		
Machine dimension (L×W×H)	m	4.2 x 1.2 x 1.5			4.2 x 1.2 x 1.5		

01. Theoretical injection volume: cross section of screw*screw stroke.
 02. The minimum mold size should be more than 70% of tie-bar distance.
 03. The specifications might be changed without any prior notice.
 04. The metering distance is recommended in the range of 1 to 3 times of screw diameter.

Model	TE110G5									
	IE125			IE260			IE370			
Injection Unit										
Screw & Barrel type		O	A	B	O	A	B	O	A	B
Screw diameter	mm	22	25	28	28	32	36	32	36	40
Injection pressure	kg/cm ²	2609	2021	1611	2676	2049	1619	2497	1973	1598
	Mpa	256	198	158	262	201	159	245	193	157
Injection holding pressure	kg/cm ²	2348	1819	1450	2408	1844	1457	2247	1776	1438
	Mpa	230	178	142	236	181	143	220	174	141
Theoretical injection volume	cm ³	48	61	77	99	129	163	145	183	226
Shot weight (PS)	g	43	56	70	90	117	148	132	167	206
Injection rate	cm ³ /s	84	108	135	123	161	204	141	178	220
Screw stroke	mm	125			160			180		
Injection speed	mm/s	220			200			175		
Plasticizing capacity (PS)	kg/h	31	44	57	45	64	92	60	86	117
	rpm	500			400			375		
Clamping Unit										
Clamping force	ton(kN)	110(1078)								
Distance between tie-bar (H×V)	mm	470 x 470								
Platen dimension (H×V)	mm	680 x 680								
Stroke	mm	400								
Max. Daylight	mm	850								
Min. mold height	mm	150								
Max. mold height	mm	450								
Ejector force	ton(kN)	3.1(31)								
Ejector stroke	mm	80								
General										
Motor capacity	kW	15			20.0			20.0		
Heater capacity	kW	4.5	5.1	5.9	7.0	7.8	9.1	8.5	9.9	11.2
Total electric power capacity	kW	19.5	20.1	20.9	27.0	27.8	29.1	28.5	29.9	31.2
Machine weight (Clamping+Injection)	ton	4.2			4.7			5.2		
Machine dimension (L×W×H)	m	4.9 x 1.3 x 2.0			4.9 x 1.3 x 2.0			4.9 x 1.3 x 2.0		

DL-G5
450~4300 ton

TB-G5
90~880 ton

TE-G5
50~400 ton

Option List
DL-G5 / TB-G5 / TE-G5

DL-G5
450~4300 ton

TB-G5
90~880 ton

TE-G5
50~400 ton

Option List
DL-G5 / TB-G5 / TE-G5

Specification **TE-G5**

Model		TE170G5								
		IE260			IE370			IE520		
Injection Unit										
Screw & Barrel type		O	A	B	O	A	B	O	A	B
Screw diameter	mm	28	32	36	32	36	40	36	40	45
Injection pressure	kg/cm ²	2676	2049	1619	2497	1973	1598	2546	2063	1630
	Mpa	262	201	159	245	193	157	250	202	160
Injection holding pressure	kg/cm ²	2408	1844	1457	2247	1776	1438	2291	1857	1467
	Mpa	236	181	143	220	174	141	225	182	144
Theoretical injection volume	cm ³	99	129	163	145	183	226	204	251	318
Shot weight (PS)	g	90	117	148	132	167	206	186	228	289
Injection rate	cm ³ /s	123	161	204	141	178	220	153	188	239
Screw stroke	mm	160			180			200		
Injection speed	mm/s	200			175			150		
Plasticizing capacity (PS)	kg/h	45	64	92	60	86	117	86	117	158
	rpm	400			375			375		
Clamping Unit										
Clamping force	ton(kN)	170(1667)								
Distance between tie-bar (H×V)	mm	570 x 570								
Platen dimension (H×V)	mm	840 x 810								
Stroke	mm	500								
Max. Daylight	mm	1000								
Min. mold height	mm	180								
Max. mold height	mm	500								
Ejector force	ton(kN)	3.5(35)								
Ejector stroke	mm	100								
General										
Motor capacity	kW	20.0			20.0			20.0		
Heater capacity	kW	7.0	7.8	9.1	8.5	9.9	11.2	9.9	11.2	12.6
Total electric power capacity	kW	27.0	27.8	29.1	28.5	29.9	31.2	29.9	31.2	32.6
Machine weight (Clamping+Injection)	ton	7			7.5			8		
Machine dimension (L×W×H)	m	5.7 x 1.6 x 2.0			5.7 x 1.6 x 2.0			5.7 x 1.6 x 2.0		

01. Theoretical injection volume: cross section of screw*screw stroke.
 02. The minimum mold size should be more than 70% of tie-bar distance.
 03. The specifications might be changed without any prior notice.
 04. The metering distance is recommended in the range of 1 to 3 times of screw diameter.

Model		TE220G5								
		IE370			IE520			IE720		
Injection Unit										
Screw & Barrel type		O	A	B	O	A	B	O	A	B
Screw diameter	mm	32	36	40	36	40	45	40	45	50
Injection pressure	kg/cm ²	2497	1973	1598	2546	2063	1630	2476	1956	1585
	Mpa	245	193	157	250	202	160	243	192	155
Injection holding pressure	kg/cm ²	2247	1776	1438	2291	1857	1467	2228	1760	1427
	Mpa	220	174	141	225	182	144	219	173	140
Theoretical injection volume	cm ³	145	183	226	204	251	318	276	350	432
Shot weight (PS)	g	132	167	206	186	228	289	251	319	393
Injection rate	cm ³ /s	141	178	220	153	188	239	188	239	295
Screw stroke	mm	180			200			220		
Injection speed	mm/s	175			150			150		
Plasticizing capacity (PS)	kg/h	60	86	117	86	117	158	94	127	171
Screw rotation speed	rpm	375			375			300		
Clamping Unit										
Clamping force	ton(kN)	220(2157)								
Distance between tie-bar (H×V)	mm	625 x 625								
Platen dimension (H×V)	mm	900 x 870								
Stroke	mm	550								
Max. Daylight	mm	1150								
Min. mold height	mm	200								
Max. mold height	mm	600								
Ejector force	ton(kN)	3.5(35)								
Ejector stroke	mm	120								
General										
Motor capacity	kW	20.0			20.0			30.0		
Heater capacity	kW	8.5	9.9	11.2	9.9	11.2	12.6	13.6	14.6	17.1
Total electric power capacity	kW	28.5	29.9	31.2	29.9	31.2	32.6	43.6	44.6	47.1
Machine weight (Clamping+Injection)	ton	9.8			10.3			10.8		
Machine dimension (L×W×H)	m	6.2 x 1.7 x 2.0			6.2 x 1.7 x 2.0			6.2 x 1.7 x 2.0		

DL-G5
450~4300 ton

TB-G5
90~880 ton

TE-G5
50~400 ton

Option List
DL-G5 / TB-G5 / TE-G5

DL-G5
450~4300 ton

TB-G5
90~880 ton

TE-G5
50~400 ton

Option List
DL-G5 / TB-G5 / TE-G5

Specification **TE-G5**

Model	TE280G5									
	IE520			IE720			IE1000			
Injection Unit										
Screw & Barrel type		O	A	B	O	A	B	O	A	B
Screw diameter	mm	36	40	45	40	45	50	45	50	55
Injection pressure	kg/cm ²	2546	2063	1630	2476	1956	1585	2830	2292	1894
	Mpa	250	202	160	243	192	155	278	225	186
Injection holding pressure	kg/cm ²	2291	1857	1467	2228	1760	1427	2547	2063	1705
	Mpa	225	182	144	219	173	140	250	202	167
Theoretical injection volume	cm ³	204	251	318	276	350	432	398	491	594
Shot weight (PS)	g	186	228	289	251	319	393	362	447	541
Injection rate	cm ³ /s	153	188	239	188	239	295	239	295	356
Screw stroke	mm	200			220			250		
Injection speed	mm/s	150			150			150		
Plasticizing capacity (PS)	kg/h	86	117	158	94	127	171	114	154	197
Screw rotation speed	rpm	375			300			270		
Clamping Unit										
Clamping force	ton(kN)	280(2745)								
Distance between tie-bar (H×V)	mm	670 x 670								
Platen dimension (H×V)	mm	980 x 970								
Stroke	mm	600								
Max. Daylight	mm	1250								
Min. mold height	mm	250								
Max. mold height	mm	650								
Ejector force	ton(kN)	4.3(43)								
Ejector stroke	mm	130								
General										
Motor capacity	kW	20.0			30.0			54.0		
Heater capacity	kW	9.9	11.2	12.6	13.6	14.6	17.1	14.6	17.1	18.7
Total electric power capacity	kW	29.9	31.2	32.6	43.6	44.6	47.1	68.6	71.1	72.7
Machine weight (Clamping+Injection)	ton	14			14.5			15		
Machine dimension (L×W×H)	m	6.9 x 1.9 x 2.0			6.9 x 1.9 x 2.0			6.9 x 1.9 x 2.0		

01. Theoretical injection volume: cross section of screw*screw stroke.
 02. The minimum mold size should be more than 70% of tie-bar distance.
 03. The specifications might be changed without any prior notice.
 04. The metering distance is recommended in the range of 1 to 3 times of screw diameter.

Model	TE280WG5									
	IE720			IE1000			IE1360			
Injection Unit										
Screw & Barrel type		O	A	B	O	A	B	O	A	B
Screw diameter	mm	40	45	50	45	50	55	50	55	60
Injection pressure	kg/cm ²	2476	1956	1585	2830	2292	1894	2562	2117	1779
	Mpa	243	192	155	278	225	186	251	208	174
Injection holding pressure	kg/cm ²	2228	1760	1427	2547	2063	1705	2306	1905	1601
	Mpa	219	173	140	250	202	167	226	187	157
Theoretical injection volume	cm ³	276	350	432	398	491	594	530	641	763
Shot weight (PS)	g	251	319	393	362	447	541	482	583	694
Injection rate	cm ³ /s	188	239	295	239	295	356	295	356	424
Screw stroke	mm	220			250			270		
Injection speed	mm/s	150			150			150		
Plasticizing capacity (PS)	kg/h	94	127	171	114	154	197	142	182	233
Screw rotation speed	rpm	300			270			250		
Clamping Unit										
Clamping force	ton(kN)	280(2745)								
Distance between tie-bar (H×V)	mm	720 x 720								
Platen dimension (H×V)	mm	1020 x 1020								
Stroke	mm	650								
Max. Daylight	mm	1350								
Min. mold height	mm	300								
Max. mold height	mm	700								
Ejector force	ton(kN)	4.3(43)								
Ejector stroke	mm	130								
General										
Motor capacity	kW	30.0			54.0			54.0		
Heater capacity	kW	13.6	14.6	17.1	14.6	17.1	18.7	19.1	21.0	23.8
Total electric power capacity	kW	43.6	44.6	47.1	68.6	71.1	72.7	73.1	75.0	77.8
Machine weight (Clamping+Injection)	ton	15.5			16.0			16.5		
Machine dimension (L×W×H)	m	7.4 x 1.9 x 2.0			7.4 x 1.9 x 2.0			7.4 x 1.9 x 2.0		

DL-G5
450~4300 ton

TB-G5
90~880 ton

TE-G5
50~400 ton

Option List
DL-G5 / TB-G5 / TE-G5

DL-G5
450~4300 ton

TB-G5
90~880 ton

TE-G5
50~400 ton

Option List
DL-G5 / TB-G5 / TE-G5

Specification **TE-G5**

Model		TE350G5								
		IE1000			IE1360			IE1700		
Injection Unit										
Screw & Barrel type		O	A	B	O	A	B	O	A	B
Screw diameter	mm	45	50	55	50	55	60	55	60	65
Injection pressure	kg/cm ²	2830	2292	1894	2562	2117	1779	2335	1962	1671
	Mpa	278	225	186	251	208	174	229	192	164
Injection holding pressure	kg/cm ²	2547	2063	1705	2306	1905	1601	2102	1766	1504
	Mpa	250	202	167	226	187	157	206	173	147
Theoretical injection volume	cm ³	398	491	594	530	641	763	713	848	995
Shot weight (PS)	g	362	447	541	482	583	694	649	772	905
Injection rate	cm ³ /s	239	295	356	295	356	424	356	424	498
Screw stroke	mm	250			270			300		
Injection speed	mm/s	150			150			150		
Plasticizing capacity (PS)	kg/h	114	154	197	142	182	233	153	196	242
	rpm	270			250			210		
Clamping Unit										
Clamping force	ton(kN)	350(3432)								
Distance between tie-bar (H×V)	mm	770 x 770								
Platen dimension (H×V)	mm	1160 x 1090								
Stroke	mm	700								
Max. Daylight	mm	1450								
Min. mold height	mm	300								
Max. mold height	mm	750								
Ejector force	ton(kN)	4.3(43)								
Ejector stroke	mm	150								
General										
Motor capacity	kW	54.0			54.0			54.0		
Heater capacity	kW	14.6	17.1	18.7	19.1	21.0	23.8	21.0	23.8	25.7
Total electric power capacity	kW	68.6	71.1	72.7	73.1	75.0	77.8	75.0	77.8	79.7
Machine weight (Clamping+Injection)	ton	16.8			17.3			17.8		
Machine dimension (L×W×H)	m	8.0 x 2.0 x 2.1			8.0 x 2.0 x 2.1			8.0 x 2.0 x 2.1		

01. Theoretical injection volume: cross section of screw*screw stroke.
02. The minimum mold size should be more than 70% of tie-bar distance.

03. The specifications might be changed without any prior notice.
04. The metering distance is recommended in the range of 1 to 3 times of screw diameter.

Model		TE400G5					
		IE1360			IE1700		
Injection Unit							
Screw & Barrel type		O	A	B	O	A	B
Screw diameter	mm	50	55	60	55	60	65
Injection pressure	kg/cm ²	2562	2117	1779	2335	1962	1671
	Mpa	251	208	174	229	192	164
Injection holding pressure	kg/cm ²	2306	1905	1601	2102	1766	1504
	Mpa	226	187	157	206	173	147
Theoretical injection volume	cm ³	530	641	763	713	848	995
Shot weight (PS)	g	482	583	694	649	772	905
Injection rate	cm ³ /s	295	356	424	356	424	498
Screw stroke	mm	270			300		
Injection speed	mm/s	150			150		
Plasticizing capacity (PS)	kg/h	142	182	233	153	196	242
	rpm	250			210		
Clamping Unit							
Clamping force	ton(kN)	400(3922)					
Distance between tie-bar (H×V)	mm	820 x 820					
Platen dimension (H×V)	mm	1240 x 1140					
Stroke	mm	750					
Max. Daylight	mm	1550					
Min. mold height	mm	350					
Max. mold height	mm	800					
Ejector force	ton(kN)	5.6(56)					
Ejector stroke	mm	210					
General							
Motor capacity	kW	54.0			54.0		
Heater capacity	kW	19.1	21.0	23.8	21.0	23.8	25.7
Total electric power capacity	kW	73.1	75.0	77.8	75.0	77.8	79.7
Machine weight (Clamping+Injection)	ton	21.5			22.0		
Machine dimension (L×W×H)	m	8.3 x 2.1 x 2.2			8.3 x 2.1 x 2.2		

DL-G5
450~4300 ton

TB-G5
90~880 ton

TE-G5
50~400 ton

Option List
DL-G5 / TB-G5 / TE-G5

DL-G5
450~4300 ton

TB-G5
90~880 ton

TE-G5
50~400 ton

Option List
DL-G5 / TB-G5 / TE-G5

Platen Dimension

TE-G5

Unit: mm

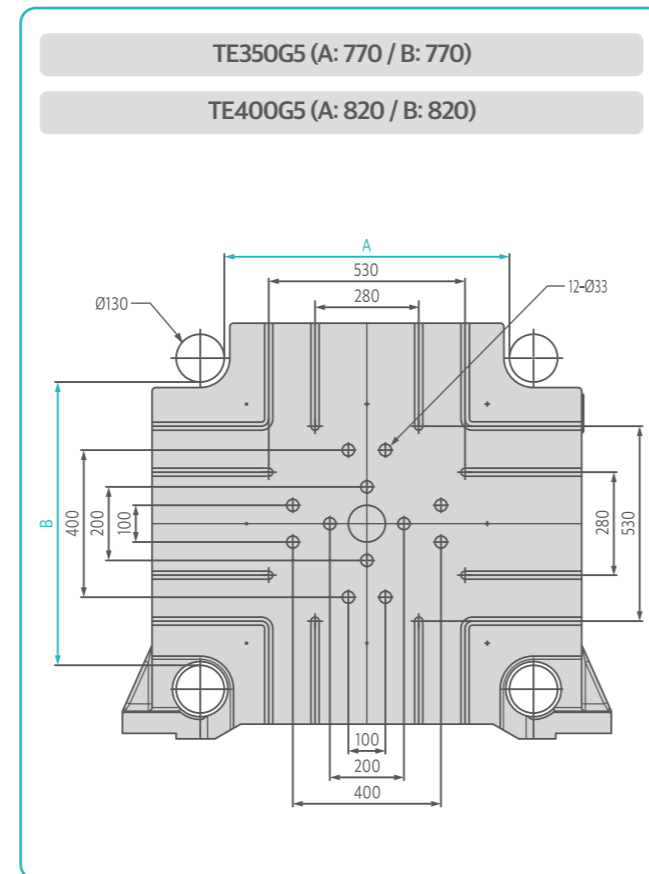
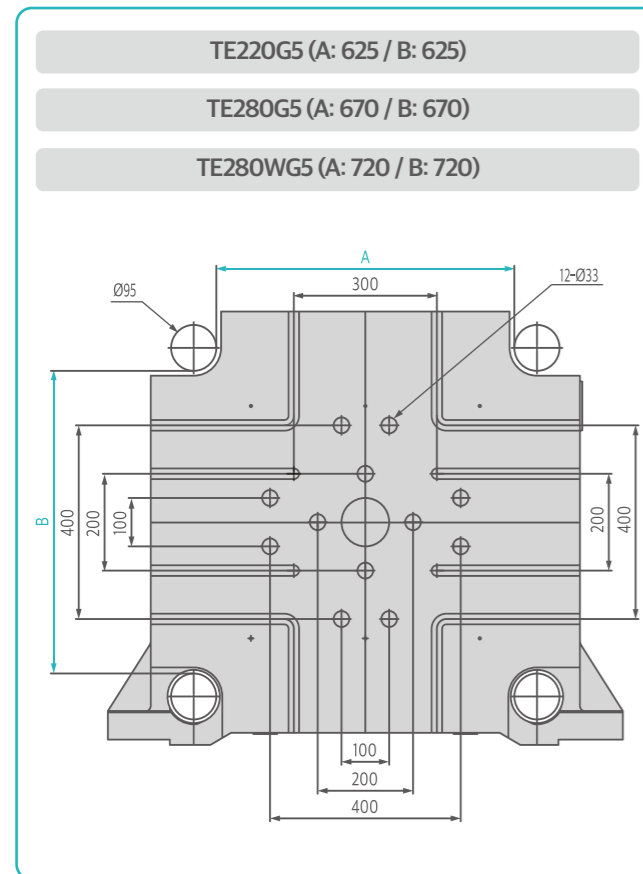
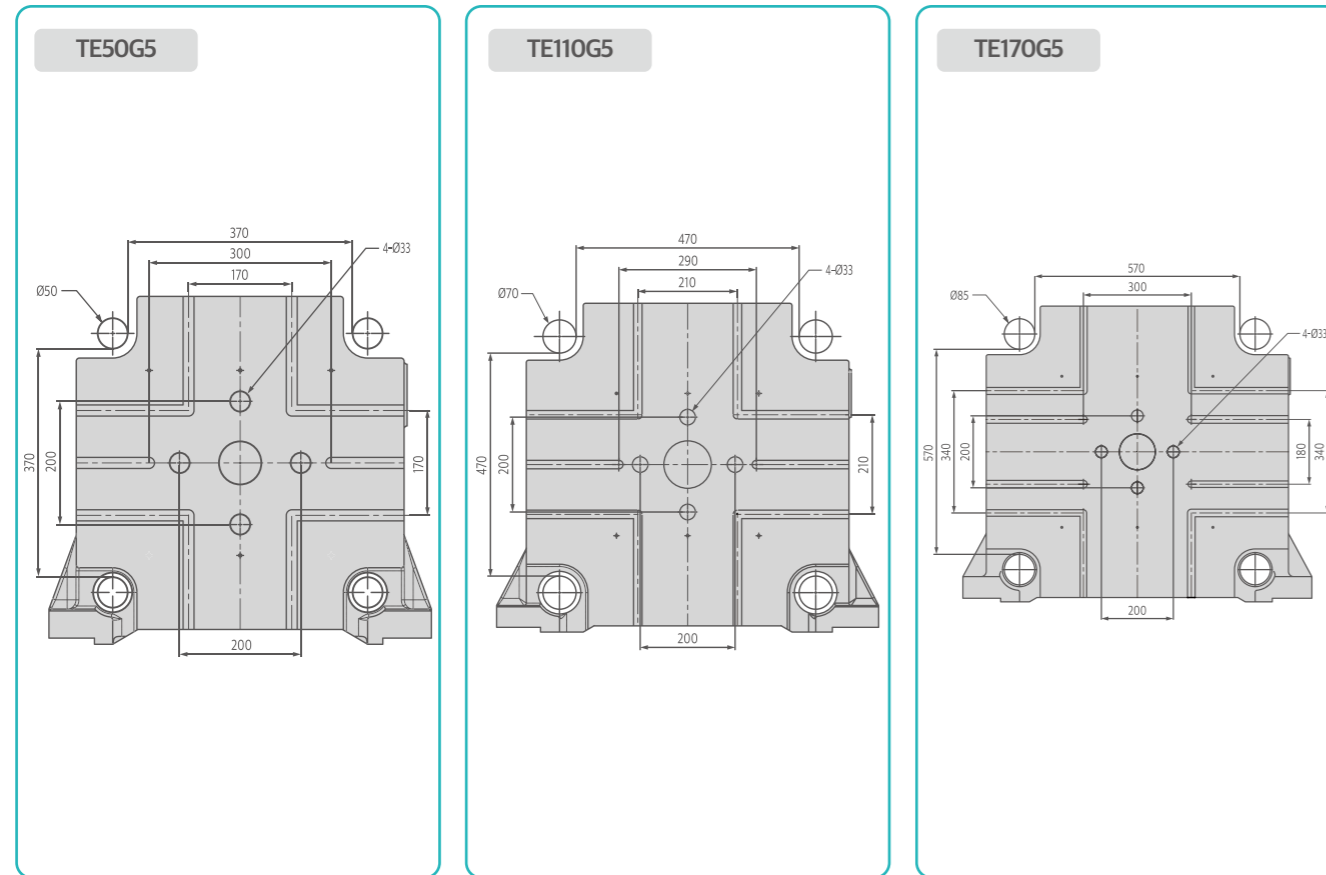

* The images and specifications might be changed without any prior notice.

Machine Dimension

TE-G5

Unit: mm

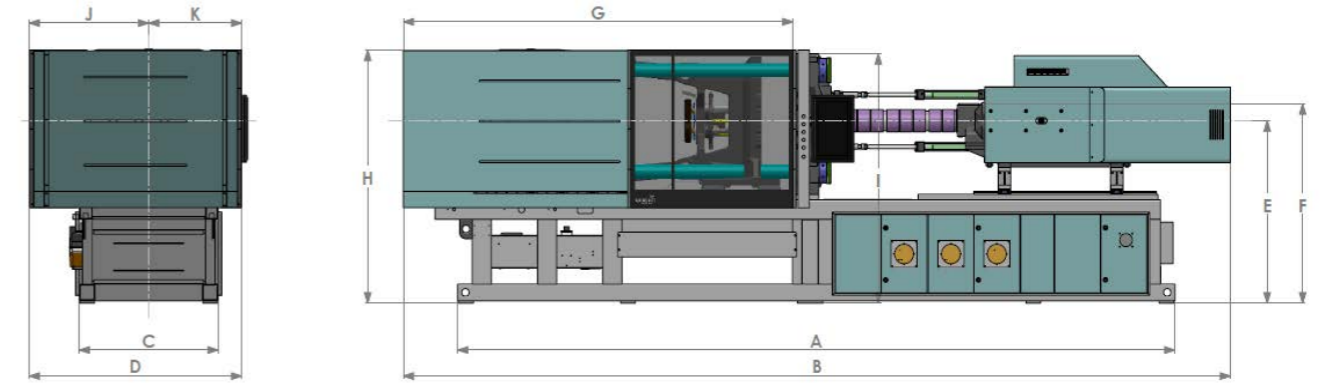

Machine Dimension											
	A	B	C	D	E	F	G	H	I	J	K
TE50G5	3855	4105	780	1136	1100	1190	1806	1454	1385	568	568
TE110G5	4270	4846	950	1237	1170	1270	2205	1962	1530	592	645
TE170G5	4965	5687	1100	1586	1240	1355	2549	1914	1680	870	716
TE220G5	5400	6157	1180	1634	1319	1434	2913	1915	1799	907	727
TE280G5	5835	6830	1240	1817	1372	1502	3144	1922	1887	1010	807
TE280WG5	6410	7308	1240	1841	1397	1527	3288	1972	1942	1013	828
TE350G5	6735	7995	1410	1926	1465	1605	3610	2100	2065	1047	879
TE400G5	7050	8293	1460	2008	1490	1630	3801	2155	2115	1053	955

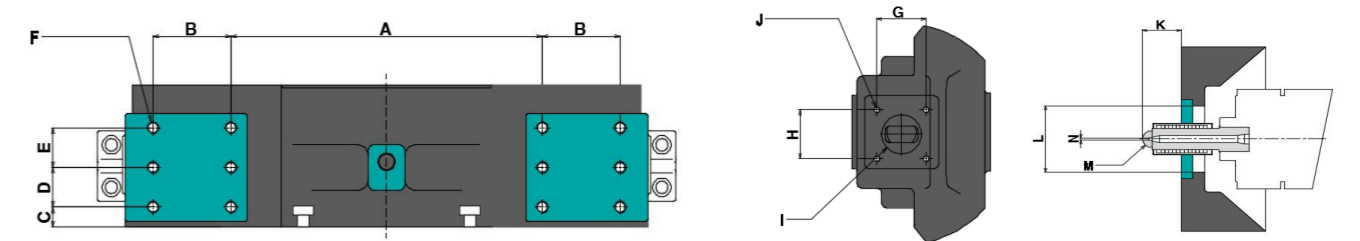

Unit: mm

	Robot installation position dimension						Hopper installation position dimension				Nozzle dimension			
	A	B	C	D	E	F	G	H	I	J	K	ØL	M	ØN
TE50G5	340	85	30	75	x	8-M16 TAP DP32	80	80	Ø70	4-M8 TAP	30	Ø100	R9	Ø2.5
TE110G5	455	85	35	70	x	8-M16 TAP DP32	100	100	Ø80	4-M12 TAP	50	Ø100	R9	Ø2.5
TE170G5	420	140	35	70	70	12-M20 TAP DP40	100	100	Ø80	4-M12 TAP	50	Ø100	R9	Ø3
TE220G5	560	140	35	70	70	12-M20 TAP DP40	100	100	Ø80	4-M12 TAP	50	Ø100	R9	Ø3
TE280G5	560	140	35	140	x	8-M20 TAP DP40	120	120	Ø100	4-M12 TAP	50	Ø100	R14	Ø3.5
TE280WG5	700	140	35	140	x	8-M20 TAP DP40	120	120	Ø100	4-M12 TAP	50	Ø100	R14	Ø3.5
TE350G5	760	150	40	150	x	8-M20 TAP DP40	120	120	Ø120	4-M12 TAP	50	Ø100	R14	Ø3.5
TE400G5	850	100	50	60	60	12-M24 TAP DP40	120	120	Ø120	4-M12 TAP	50	Ø100	R14	Ø3.5

* The images and specifications might be changed without any prior notice.

DL-G5
450~4300 ton

TB-G5
90~880 ton

TE-G5
50~400 ton

Option List
DL-G5 / TB-G5 / TE-G5

DL-G5
450~4300 ton

TB-G5
90~880 ton

TE-G5
50~400 ton

Option List
DL-G5 / TB-G5 / TE-G5

Option List DL-G5 (ver.1)

* This page is provided for customer's better understanding.
 * Automatic swiveling function may not be applicable when not using standard injection unit.

Injection Unit	Clamping Unit	General
Standard		
01. Single Flight Screw	01. Safety Foot-board (Above 1050ton)	01. Standard Maintenance tools
02. Injection valve gate circuit (AC 1 + DC 1)	02. Automatic safety Door open/close (Above 450ton)	02. Standard spare part
03. Back-Pressure Closed-loop system	03. Clamping area Curtain sensor (Above 550ton)	03. Leveling pad
04. PID Heating Control	04. Hydraulic Core puller (Moving platen side, 1 stage)	04. Cooling water distributor
05. Weekly Heating Timer	05. Air blow-off unit (Fixed side 1 + Moving side 1)	05. Automatic grease lubrication (Clamping)
06. Cold screw start protection mode	06. Safety device (for electric & hydraulic)	06. Robot interface (Standard)
07. Temperature display & Alarm in abnormal Temp.	07. Spring mold mode	07. 3 Phase electric outlet (2 ea)
08. Auto Purging	08. Automatic Mold thickness adjust mode	08. Single Phase electric outlet (1 ea)
09. Injection Speed & Pressure step (10 step)	09. Mold-Open Speed & Pressure step (5 step)	09. Steel tray for resin leakage
10. Holding Speed & Pressure step (5 step)	10. Ejector Speed & Pressure step (3 step)	10. Hopper throat temperature control device
11. Charging Speed & Pressure step (4 step)		11. Hydraulic oil purification device
12. Back Pressure control step (4 step)		12. Hydraulic oil temperature control device
13. Injection Pressure Graph Display		13. Hydraulic oil level alarm
14. Injection Speed Graph Display		14. Hydraulic oil temperature check & alarm
15. Screw RPM Display		15. Hydraulic oil heating mode
16. Cushion Display & Alarm		16. 3 color alarm light
17. Charging time count & alarm		17. Shot data saving by external way
18. Screw & Barrel (Anti Wear)		18. Production data statistics
		19. Alarming & History save
		20. Log history save
		21. I/O circuit display
		22. Shot data save (Internal 1,000 / External device)
Option		
01. Heater Disconnection check device	01. Rotating Core Circuit	01. Hydraulic Auto-Clamp unit
02. Hopper Slide (L/M)	02. Safety Foot-board (Below 850ton)	02. Anchor-bolt set (Clamping unit)
03. Hopper Ladder & Stand	03. Ejector Check Valve	03. Heater Insulation Band
04. Screw & Barrel (Nitrided barrel)	04. Core & Ejector on Fly	04. Automatic Grease Lubrication (Injection unit)
05. Screw & Barrel (Anti Wear & Corrosive)	05. Hydraulic Core Check Valve	05. Robot Interface (EM12, EM 67, EM67.1, SPI)
06. Valve Gate Circuit & Connector (Interior type)	06. Core Pressure release Circuit (Manual)	06. CMS (Central Monitoring System)
07. Hydraulic Valve Gate Block (Interior type)	07. Ejector Interlock Connector (WJ Standard, EM13)	07. AVR (Automatic Voltage Regulator) on Electric Panel
08. Pneumatic Valve Gate Block (Interior type)	08. Hydraulic Core Interlock Connector (EM13, WJ Standard)	08. UPS (Uninterruptable Power Supply) on Electric Panel
09. Hydraulic Valve Gate Device (External device)	09. Hydraulic Core Puller (2~4 Stages)	09. Dosing unit Interface (for Masterbatch)
10. Charging on Fly (AC Motor)	10. Pneumatic Core Puller (1-3 Stages)	10. Gas Injection Interface
11. Shut-off Nozzle (Pneumatic, Hydraulic, Spring)	11. tie-bar pulling (2300ton~)	11. Steam Injection Interface
12. Customized Design Screw (SB, Mixing, Coating)	12. Ejector Forward / Backward External switch	12. External Temperature Display (F/P)
	13. Mold Insulation Plate	13. Interior type Hot Runner Controller (EM14, WJ Standard)
	14. Mold ring on Moving-Platen	
	15. Daylight Extension	
	16. Product Chute	

Option List DL-G5 (ver.2)

* This page is provided for customer's better understanding.
 * Automatic swiveling function may not be applicable when not using standard injection unit.

Injection Unit	Clamping Unit	General
Standard		
01. Single Flight Screw	01. Safety Foot-board (Above 1050ton)	01. Standard Maintenance tools
02. Injection valve gate circuit (AC 1 + DC 1)	02. Automatic safety Door open/close (Above 450ton)	02. Standard spare part
03. Back-Pressure Closed-loop system	03. Clamping area Curtain sensor (Above 550ton)	03. Leveling pad
04. PID Heating Control	04. Hydraulic Core puller (Moving platen side, 1 stage)	04. Cooling water distributor
05. Weekly Heating Timer	05. Air blow-off unit (Fixed side 1 + Moving side 1)	05. Automatic grease lubrication (Clamping)
06. Cold screw start protection mode	06. Safety device (for electric & hydraulic)	06. Robot interface (Standard)
07. Temperature display & Alarm in abnormal Temp.	07. Spring mold mode	07. 3 Phase electric outlet (2 ea)
08. Auto Purging	08. Automatic Mold thickness adjust mode	08. Single Phase electric outlet (1 ea)
09. Injection Speed & Pressure step (10 step)	09. Mold-Open Speed & Pressure step (5 step)	09. Steel tray for resin leakage
10. Holding Speed & Pressure step (5 step)	10. Ejector Speed & Pressure step (3 step)	10. Hopper throat temperature control device
11. Charging Speed & Pressure step (4 step)		11. Hydraulic oil purification device
12. Back Pressure control step (4 step)		12. Hydraulic oil temperature control device
13. Injection Pressure Graph Display		13. Hydraulic oil level alarm
14. Injection Speed Graph Display		14. Hydraulic oil temperature check & alarm
15. Screw RPM Display		15. Hydraulic oil heating mode
16. Cushion Display & Alarm		16. 3 color alarm light
17. Charging time count & alarm		17. Shot data saving by external way
18. Screw & Barrel (Anti Wear)		18. Production data statistics
		19. Alarming & History save
		20. Log history save
		21. I/O circuit display
		22. Shot data save (Internal 1,000 / External device)
Option		
01. Heater Disconnection check device	01. Rotating Core Circuit	01. Hydraulic Auto-Clamp unit
02. Hopper Slide (L/M)	02. Safety Foot-board (Below 850ton)	02. Anchor-bolt set (Clamping unit)
03. Hopper Ladder & Stand	03. Ejector Check Valve	03. Heater Insulation Band
04. Screw & Barrel (Nitrided barrel)	04. Core & Ejector on Fly	04. Automatic Grease Lubrication (Injection unit)
05. Screw & Barrel (Anti Wear & Corrosive)	05. Hydraulic Core Check Valve	05. Robot Interface (EM12, EM 67, EM67.1, SPI)
06. Valve Gate Circuit & Connector (Interior type)	06. Core Pressure release Circuit (Manual)	06. CMS (Central Monitoring System)
07. Hydraulic Valve Gate Block (Interior type)	07. Ejector Interlock Connector (WJ Standard, EM13)	07. AVR (Automatic Voltage Regulator) on Electric Panel
08. Pneumatic Valve Gate Block (Interior type)	08. Hydraulic Core Interlock Connector (EM13, WJ Standard)	08. UPS (Uninterruptable Power Supply) on Electric Panel
09. Hydraulic Valve Gate Device (External device)	09. Hydraulic Core Puller (2~4 Stages)	09. Dosing unit Interface (for Masterbatch)
10. Charging on Fly (AC Motor)	10. Pneumatic Core Puller (1-3 Stages)	10. Gas Injection Interface
11. Shut-off Nozzle (Pneumatic, Hydraulic, Spring)	11. tie-bar pulling	11. Steam Injection Interface
12. Customized Design Screw (SB, Mixing, Coating)	12. Ejector Forward / Backward External switch	12. External Temperature Display (F/P)
	13. Mold Insulation Plate	13. Interior type Hot Runner Controller (EM14, WJ Standard)
	14. Mold ring on Moving-Platen	
	15. Daylight Extension	
	16. Product Chute	

DL-G5
450~4300 ton

TB-G5
90~880 ton

TE-G5
50~400 ton

Option List
DL-G5 / TB-G5 / TE-G5

DL-G5
450~4300 ton

TB-G5
90~880 ton

TE-G5
50~400 ton

Option List
DL-G5 / TB-G5 / TE-G5

Option List TB-G5

* This page is provided for customer's better understanding.

Injection Unit	Clamping Unit	General
Standard		
01. Single Flight Screw 02. Injection valve gate circuit (AC 1 + DC 1) 03. Back-Pressure Closed-loop system 04. PID Heating Control 05. Weekly Heating Timer 06. Cold screw start protection mode 07. Temperature display & Alarm in abnormal Temp. 08. Auto Purging 09. Injection Speed & Pressure step (10 step) 10. Holding Speed & Pressure step (5 step) 11. Charging Speed & Pressure step (4 step) 12. Back Pressure control step (4 step) 13. Injection Pressure Graph Display 14. Injection Speed Graph Display 15. Screw RPM Display 16. Cushion Display & Alarm 17. Charging time count & alarm 18. Screw & Barrel (Anti Wear)	01. Automatic safety Door open/close (Above 480ton) 02. Mold thickness adjusting brake unit (Below 580ton) 03. Hydraulic Core puller (Moving platen side, 1 stage) 04. Air blow-off unit (Fixed side 1 + Moving side 1) 05. Safety device (for electric & hydraulic) 06. Automatic Mold thickness adjust mode 07. Mold-Open Speed & Pressure step (5 step) 08. Mold-Close Speed & Pressure step (5 step) 09. Ejector Speed & Pressure step (3 step)	01. Standard Maintenance tools 02. Standard spare part 03. Leveling pad 04. Cooling water distributor 05. Automatic oil lubrication (Toggle) 06. Robot interface (Standard) 07. 3 Phase electric outlet (2 ea) 08. Single Phase electric outlet (1 ea) 09. Hopper throat temperature control device 10. Hydraulic oil purification device 11. Hydraulic oil temperature control device 12. Hydraulic oil level alarm 13. Hydraulic oil temperature check & alarm 14. Hydraulic oil heating mode 15. 3 color alarm light 16. Shot data saving by external way 17. Production data statistics 18. Alarming & History save 19. Log history save 20. I/O circuit display 21. Shot data save (Internal 1,000 / External device)
Option		
01. Heater Disconnection check device 02. Hopper Slide (L/M) 03. Screw & Barrel (Nitrided barrel) 04. Screw & Barrel (Anti Wear & Corrosive) 05. Valve Gate Circuit & Connector (Pneumatic, Hydraulic, Spring) 06. Shut-off Nozzle (Pneumatic, Hydraulic, Spring) 07. Customized Design Screw (SB, Mixing, Coating)	01. Rotating Core Circuit 02. Daylight Extension 03. Automatic safety Door open/close (Below 380ton) 04. Ejector Check Valve 05. Hydraulic Core Check Valve 06. Core Pressure release Circuit (Manual) 07. Ejector Interlock Connector (WJ Standard, EM13) 08. Hydraulic Core Interlock Connector (EM13, WJ Standard) 09. Hydraulic Core Puller (2~4 Stages) 10. Pneumatic Core Puller (1-3 Stages) 11. Ejector Forward / Backward External switch 12. Mold Insulation Plate 13. Product Chute 14. Mold ring on Moving-Platen	01. Lubricating oil Recycling device 02. Product drop check device 03. Product quality sorting device 04. Hydraulic Auto-Clamp unit 05. Steel tray for resin leakage 06. Heater Insulation Band 07. Automatic Grease Lubrication (Clamping unit) 08. Automatic Grease Lubrication (Injection unit) 09. Robot Interface (EM12, EM67, EM67.1, SPI) 10. CMS (Central Monitoring System) 11. AVR (Automatic Voltage Regulator) on Electric Panel 12. UPS (Uninterruptible Power Supply) on Electric Panel 13. Dosing unit Interface (for Masterbatch) 14. Gas Injection Interface 15. Steam Injection Interface 16. External Temperature Display (F/P) 17. Interior type Hot Runner Controller (EM14, WJ Standard)

Option List TE-G5

* This page is provided for customer's better understanding.

Injection Unit	Clamping Unit	General
Standard		
01. Single Flight Screw 02. Charging on Fly 03. Injection valve gate circuit (AC 1 + DC 1) 04. Back-Pressure Closed-loop system 05. PID Heating Control 06. Weekly Heating Timer 07. Cold screw start protection mode 08. Temperature display & Alarm in abnormal Temp. 09. Auto Purging 10. Injection Speed & Pressure step (10 step) 11. Holding Speed & Pressure step (5 step) 12. Charging Speed & Pressure step (4 step) 13. Back Pressure control step (4 step) 14. Back Pressure control step (3 step) 15. Injection Pressure Graph Display 16. Injection Speed Graph Display 17. Screw RPM Display 18. Cushion Display & Alarm 19. Charging time count & alarm 20. Screw & Barrel (Anti Wear)	01. Ejecting on fly 02. Air blow-off unit (Fixed side 1 + Moving side 1) 03. Safety device (for electric & hydraulic) 04. Automatic Mold thickness adjust mode 05. Mold-Open Speed & Pressure step (5 step) 06. Mold-Close Speed & Pressure step (5 step) 07. Ejector Speed & Pressure step (3 step)	01. Standard Maintenance tools 02. Standard spare part 03. Leveling pad 04. Cooling water distributor 05. Automatic Ball-screw grease lubrication (All parts) 06. Automatic oil lubrication (Toggle) 07. Robot interface (Standard) 08. 3 Phase electric outlet (2 ea) 09. Single Phase electric outlet (1 ea) 10. Hopper throat temperature control device 11. 3 color alarm light 12. Shot data saving by external way 13. Production data statistics 14. Alarming & History save 15. Log history save 16. I/O circuit display 17. Shot data save (Internal 1,000 / External device)
Option		
01. Heater Disconnection check device 02. Hopper Slide (L/M) 03. Long-holding pressure type upgrade 04. Screw & Barrel (Nitrided barrel) 05. Screw & Barrel (Anti Wear & Corrosive) 06. Valve Gate Circuit & Connector (Interior type) 07. Pneumatic Valve Gate Block (Interior type) 08. Shut-off Nozzle (Pneumatic, Hydraulic, Spring) 09. Customized Design Screw (SB, Mixing, Coating)	01. Rotating Core Circuit 02. Automatic clamping force measurement compensation mode 03. Core on Fly 04. Mold ring on Moving-Platen 05. Daylight Extension 06. Automatic safety Door open/close 07. Core-Back Mode 08. Ejector Interlock Connector (WJ Standard, EM13) 09. Ejector Forward / Backward External switch 10. Hydraulic Core Interlock Connector (EM13, WJ Standard) 11. Hydraulic Core Device (Fixed, Moving, 1 or 2 stage) 12. Pneumatic Core Puller (1-3 Stages) 13. Mold Insulation Plate 14. Product Chute	01. Lubricating oil Recycling device 02. Product drop check device 03. Product quality sorting device 04. Hydraulic Auto-Clamp unit 05. Steel tray for resin leakage 06. Heater Insulation Band 07. Robot Interface (EM12, EM67, EM67.1, SPI) 08. CMS (Central Monitoring System) 09. AVR (Automatic Voltage Regulator) on Electric Panel 10. UPS (Uninterruptible Power Supply) on Electric Panel 11. Dosing unit Interface (for Masterbatch) 12. Gas Injection Interface 13. Steam Injection Interface 14. External Temperature Display (F/P) 15. Interior type Hot Runner Controller (EM14, WJ Standard)

DL-G5
450~4300 ton

TB-G5
90~880 ton

TE-G5
50~400 ton

Option List
DL-G5 / TB-G5 / TE-G5

DL-G5
450~4300 ton

TB-G5
90~880 ton

TE-G5
50~400 ton

Option List
DL-G5 / TB-G5 / TE-G5

SPEED CLUB

Customer Service

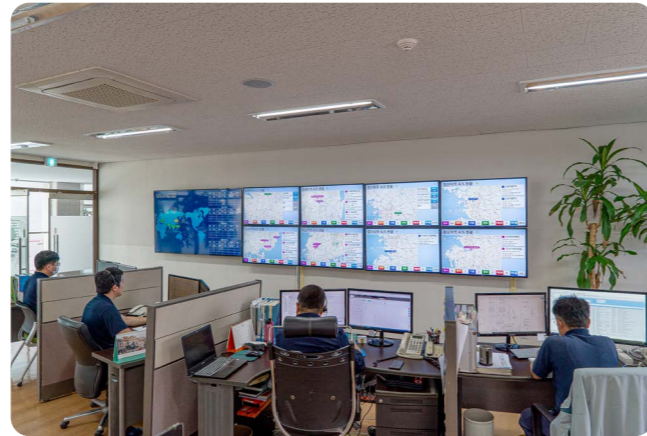
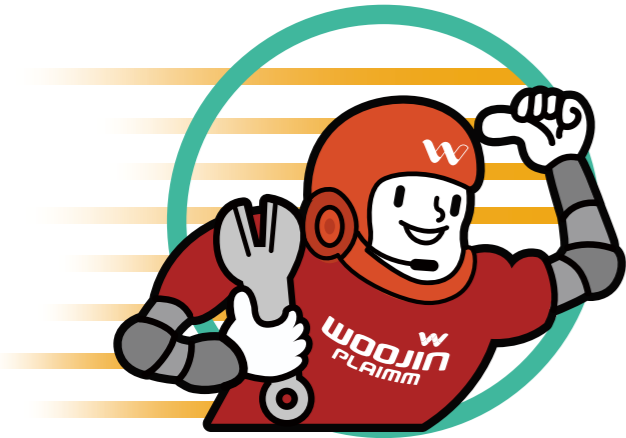

Dispatches A/S team within 24 hours

Our A/S experts will immediately diagnose the issue by the APP and reach your place within 24 hours.

Dedicated B/S(Before service) team

Our B/S experts routinely visit customers to check condition of machine and to provide them with technical advice, so that we can ensure maximized productivity of the machines we supplied.

Mobile phone based APP support

Customers can review A/S progress in real time and manage the process.

Warranty extension

We insure quality of main parts.

CS center process screen

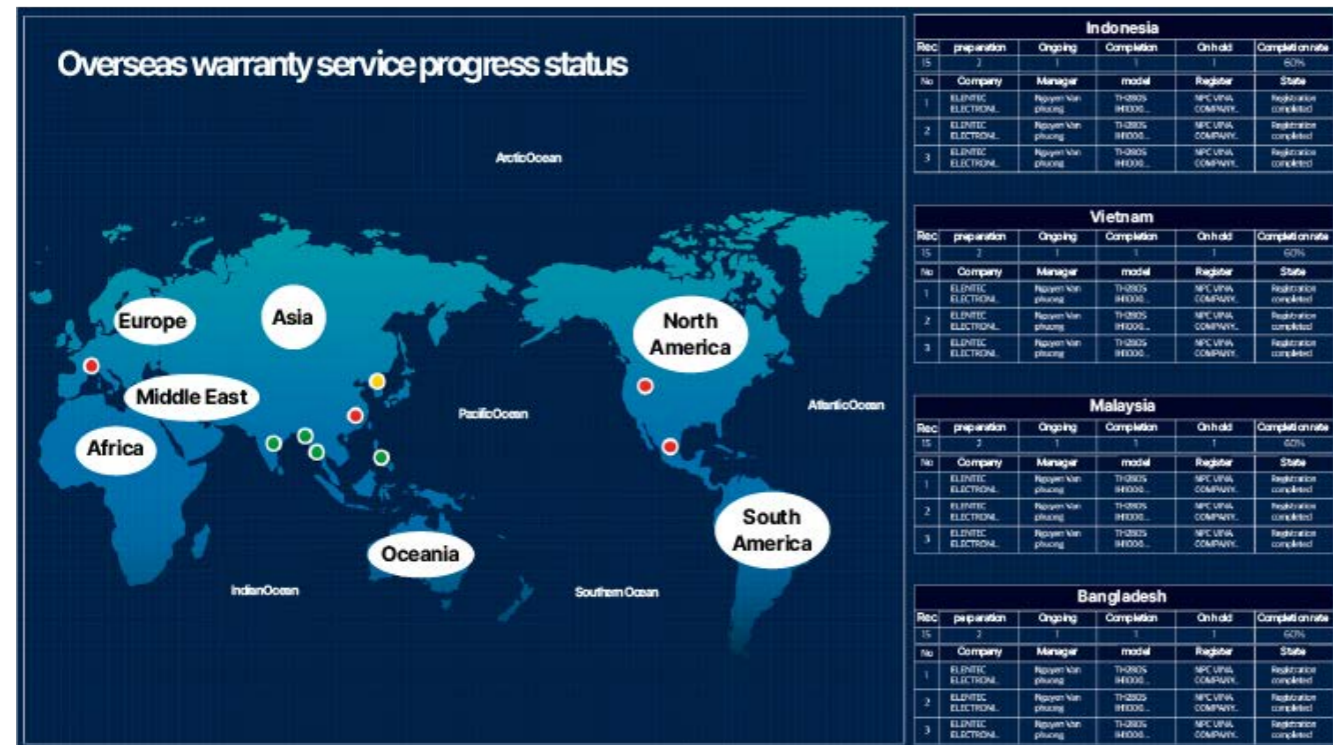

We operate an integrated CS control tower for real-time monitoring of SPEED CLUB mobile application and efficient service. Experts from each field are always on standby to assign technically qualified engineers through real-time meetings.

SPEED CLUB customer care service

01. What is SPEED CLUB application?

You can experience a variety of convenient services, from technical consultation and A/S reception to injection molding experts, real-time status check, and service result history inquiry, available anytime, anywhere.

SPEED CLUB App service process

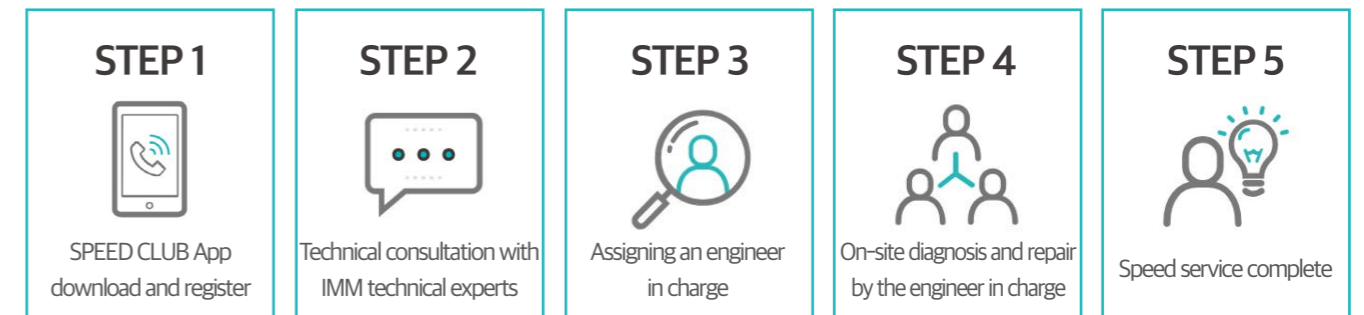

Application main functions





HQ

WOOJIN PLAIMM
 100, woojinplaimm-ro, jangan-myeon, boeun-gun,
 chungcheongbuk-do, Korea
 T. +82. 43. 540. 9000
 F. +82. 43. 543. 1420
 E. info@wjpim.com

Sister Companies

U.S.A Inc. Chicago. +1. 847. 457. 1916 Atlanta. +1. 224. 500. 8138 Detroit. +1. 224. 500. 5085 E. us@wjpim.com	Mexico Inc. Monterrey. +52. 81. 4452. 0851 Queretaro. +52. 181. 1555. 4286 Tijuana. +52. 181. 1555. 4224 E. mx@wjpim.com	China Inc. Ningbo. +86. 574. 8680. 6088 Guangdong. +86. 13549382580 Suzhou. +86. 070. 7001. 3228 E. cn@wjpim.com
--	--	--

Austria Inc. Vienna. +43. 2256. 20413
E. office@woojin.at

Branch Office

Thailand Branch Bangkok. +66. 2. 745. 4746 Chonburi. +66. 33. 138. 848 E. th@wjpim.com	Vietnam Branch Bacninh. +84. 22. 23906. 797 Hochiminh. +84. 28. 3772. 0028 E. vn@wjpim.com	India Branch Chennai. +91. 77081. 80333 Anantapur. +91. 77081. 54222 E. in@wjpim.com
Malaysia Branch Kuala Lumpur. +60. 3. 7887. 0590 Johor Bahru. +60. 12. 631. 2192 E. my@wjpim.com	Indonesia Branch Jakarta. +62. 21. 8370. 1281 Cikarang. +62. 21. 8992. 4411 E. id@wjpim.com	Japan Branch Nagoya. +81. 52. 919. 7775 Omiya. +81. 90. 6689. 1754 E. jp@wjpim.com
Russia Branch Moscow. +7. 495. 245. 0073 E. ru@wjpim.com	Bangladesh Branch Dhaka. +880. 19. 2563. 7935 E. bd3@wjpim.com	Poland Branch Katowice. +48. 513. 211. 177 E. ploffice@wjpim.com
Slovakia Branch Zilina. +421. 903. 207. 420 E. sk@wjpim.com	Philippines Branch Manila. +63. 2. 8822. 2979 E. ph@wjpim.com	Türkiye Branch Istanbul. +90. 216. 290. 1483 E. tr@wjpim.com

MEMO





CopyRight© 2025, WOOJIN PLAIMM Co.,Ltd

The brochure is protected by copyright.

Any utilization, which is not expressly permitted under copyright legislation, requires the prior approval of WOOJIN PLAIMM

Vol. 2

* The product images and specifications might be changed without any prior notice for optional purpose and/or quality improvement.
* This is an updated content as of June 1st, 2025. (The specifications may differ from the actual selling device.)